



Design and development of human factors based shoe midsole using additive manufacturing

D.Rambabu ^{1*}, R.Hariharan², A. Karthik Nambi ¹, R.Nataraj ¹, G.B.Bhaskar ¹

¹ Department of Mechanical Engineering, Tagore Engineering College, Chennai - 127

² Department of Mechanical Engineering, Bharath University, Chennai – 73

*Corresponding author E-mail: rambabu.deva@gmail.com

Copyright © 2014 D.Rambabu et al. This is an open access article distributed under the [Creative Commons Attribution License](#), which permits unrestricted use, distribution, and reproduction in any medium, provided the original work is properly cited.

Abstract

The objective of this research is to design and prototype a shoe midsole which bears enough weight of the wearer and absorbs impact forces, at same time being light weight on the aspect of material used and design. The whole design is based on human factors and requirements which were studied using a survey among a group, based on product development guidelines as a part of product lifecycle management. The design conceptualizes the use of gas as the weight bearer and impact absorber by being compactly pressurized in separate pockets, the pockets are intricately placed to optimize force absorption and maintain stability. The prototype is build using additive manufacturing technique which enabled to design with complexity. Thus a highly comfortable and ergonomically better shoe sole design was achieved; this helped in meeting the customer requirements.

Keywords: Shoe Midsole; Human Factors Based Design; Prototyping; Additive Manufacturing.

1. Introduction

The research deals to develop a mid-sole for running shoes [1, 2] based on human factors. The mid sole is important because improperly cushioning and improperly supporting midsole may lead to running injuries which affects the heel and knee. The mid sole's is the region of the shoe which absorbs shock and supports the load of the wearer; both these qualities require contradicting characteristics like stiff and rigid material to support and at the same time to be soft and compressible. To meet these basic criteria we choose two materials one is gas and the other is hard rubber or rubber like materials.

The mid sole of a shoe is responsible for the support and cushioning. This research leads to the usage of the gas and Urethane plastic in combination. The mid sole can be made out using flexible plastic material and the gas is pressurized into this system [3]. This pressurized gas is compressible hence will absorb the forces while the flexible plastic chamber is multiply divided to maximize the support and to reduce the wastage of the material. The placement of the chambers is based on the pressure acting areas in a foot wear based on the company norms and survey.

2. Human factors surveyed

We surveyed a 100 members of both genders based on the following factors which were helpful in studying the preferences of people [4, 5]. The data was correlated in useful manner for the development of the midsole.

- Pressure areas Weight
- Shoe Size
- Walking and Running speeds
- Sole hardness and absorptive capacity Daily walking distance

2.2. Conclusions from the survey

Using the inputs given by the surveyed people on the above topics the following table and the figures were developed. Below figure and charts shows a comparison between each and everything on which the final design is being made out.

2.3. Pressure areas

The fig.1 depicts a foot and the major pressure is shown in white colour. The following are the inputs given by the members when they were asked, "Where do they feel maximum pressure" and the numbers represent various inputs given by them. 55 people feel they have pressure at heel, 35 at forefoot and 10 at mid-foot.

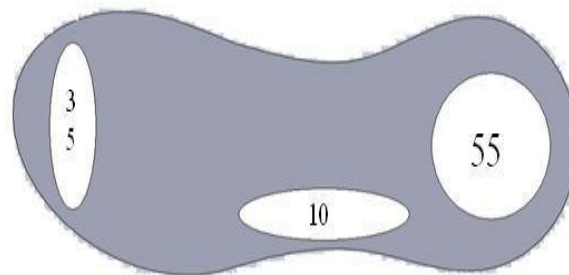

Fig. 1: Pressure Areas on the Sole

2.4. Relation between weight and Size

People's using a certain size of shoe need not be of the same weight thus, the following table shows the relationship between the weight and size, where in the horizontal direction the weights are mentioned and in the vertical direction the various sizes are mentioned. The weight varies from 40-100(above) and are in Kilograms, the sizes vary from 6-11 and are in inches. These data help in deciding how much weight a shoe should bear.

Table 1: Relation between Weight and Size

Weight/ Size	40	50	60	70	80	90-100	100 & above	Total
6	2	-	-	-	-	-	-	2
7	5	10	6	3	-	-	-	24
8	-	5	11	8	7	-	-	31
9	-	-	8	6	4	6	-	24
10	-	-	-	-	7	5	2	14
11	-	-	-	-	-	2	3	5
Total	7	15	25	17	18	13	5	100

2.5. Walking and running speeds

The following bar chart represents various running and walking speeds of the members. The total members in vertical and speeds in horizontal (Km/Hr.).

2.6. Sole stiffness and absorptive capacity

From the factors sole stiffness, the absorptive capacity and their inter-relation, we developed the following combination of the bar and pie chart. In the fig.3 the pie which represents the sole stiffness such as soft, moderate, hard and the bar chart represents the absorptive capacity. The numbers depict the member's choice. This comparison is made to study the relative choice of the members between sole stiffness and sole absorption quality preference.

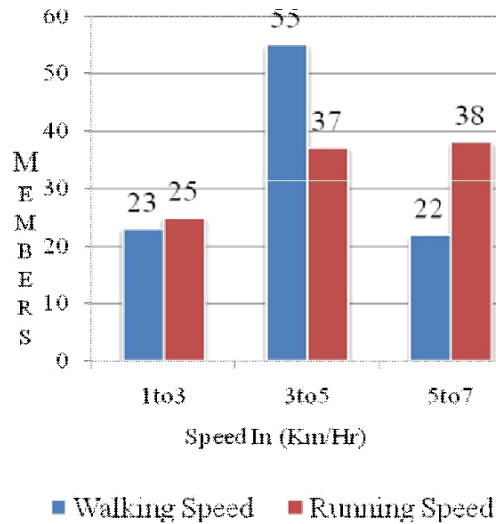

Fig. 2: Walking and Running Speeds of Humans-Comparison

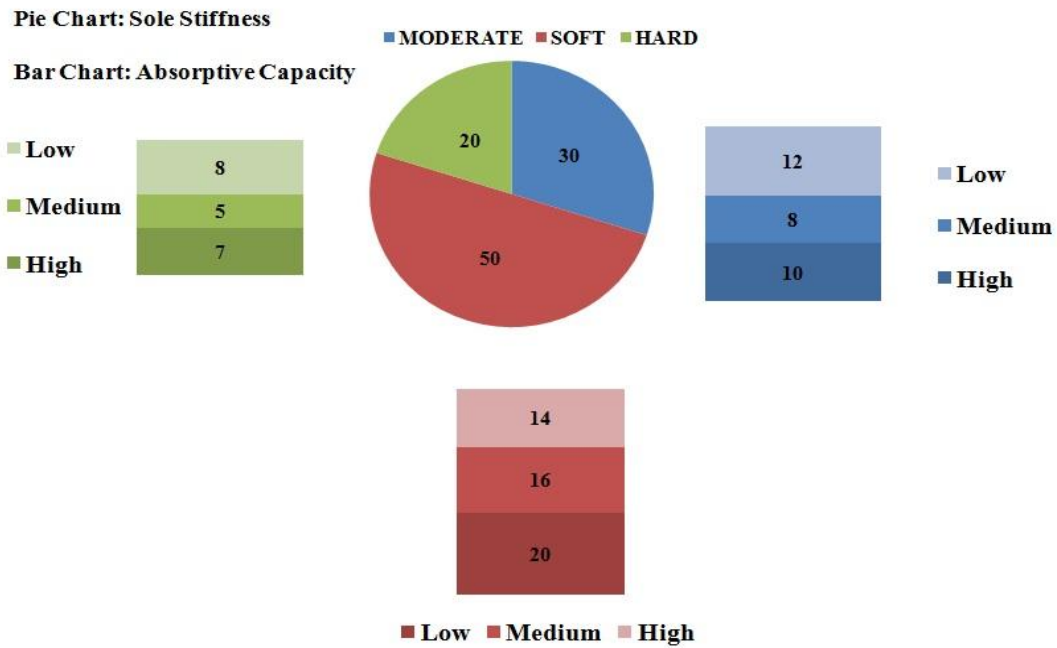

Fig. 3: Sole Stiffness and Absorptive Capacity Felt by Peoples

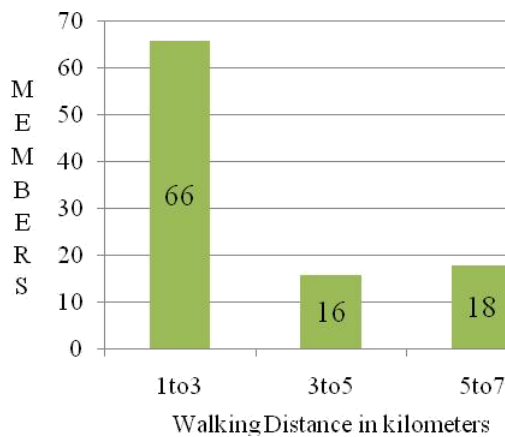

Fig. 4: Daily Walking Distances of Persons

2.7. Daily walking distance

The following bar chart represents the people's daily walking distances. This is plotted between number of members and their walking distance on daily basis [6]. The numbers inside the bars represents the number of people who come under corresponding categories.

3. Designing

The designing of the Shoe mid sole is made out using Solid Works software. The human requirements from the survey are considered and design is done based on it. The following diagrams represent various sections of the mid sole and the descriptions for the each design are given under them [7, 8].

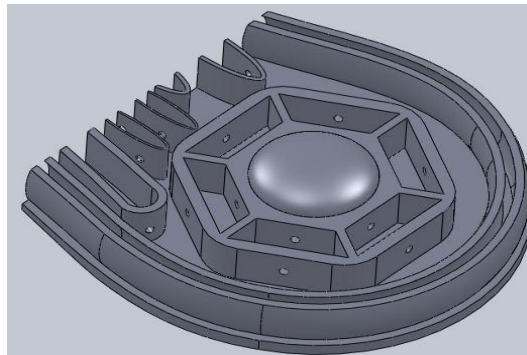

Fig. 6: Heel Strike Absorption Area

The figure 6 represents the heel strike absorption area with a dome shape, high enough to make contact with the foot above the inner sole this dome shape is surrounded by hexagonal shaped pocket during impact the gas inside the dome is being pushed outward through holes and dispersed the entire reaction allows the absorption of the force. The hexagonally split pocket enables the spread of gas equally in all direction which creates more stability by reducing distortion of shape in a particular direction.

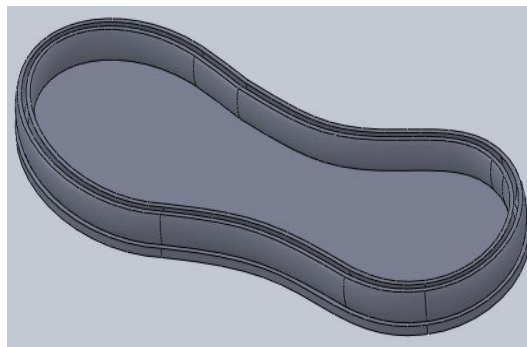

Fig. 7: The Outer Basic Support Element

The figure 7 represents the outer gas pocket along the entire outline of sole which is at a higher pressure to support the weight and maintain enough stiffness to hold the foot in a stable position to prevent from over pronation and supination.

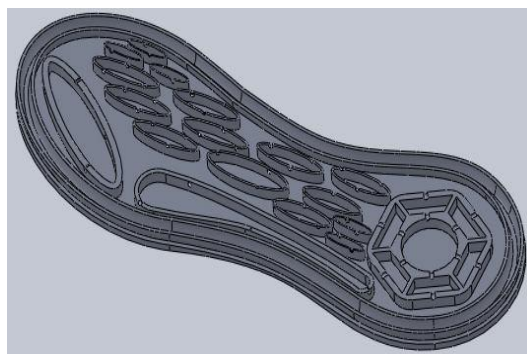

Fig. 8: Cut Section View from Top

The figure 8 reveals the entire internal structure of the system along with the holes which facilitate gas movement along the internal compartment to provide cushioning effect by damping gas flow within internal pockets and the large pocket under the dome which acts as the heel strike absorber [9].

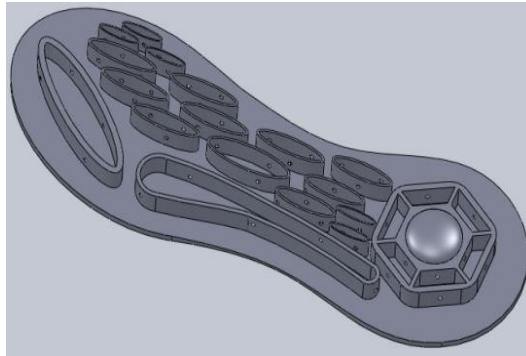

Fig. 9: Arrangement of Strike Absorption Elements

The figure 9 shows the arrangement of the inner absorption cavities which are intricately placed based on the pressure areas identified through survey and the general available data.



Fig. 10: The Bottom Sole Design

The figure 10 shows the sole bottom in which there is a cut along the mid-foot to reduce the area of contact on ground.

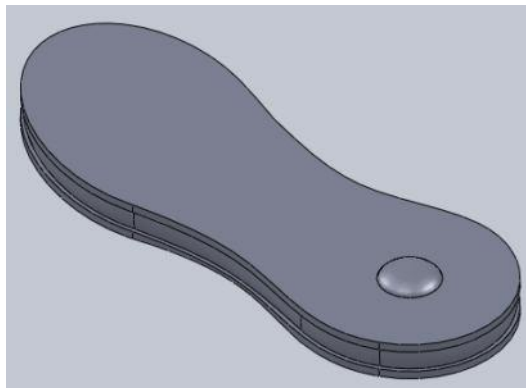

Fig. 11: Full Completed Mid-Sole Design

The figure 11 shows the full mid-sole design, which is being close at the top and the cushioning material are placed between the top and bottom part.

4. Prototype

The model of the sole is prototyped through rapid prototyping technology [10, 11] due its complex design and the time consumption involved to make a pattern and model. The additive manufacturing machine used for building the prototype is from Objet Eden350V Fig 9. The prototype is made up of rubber like material available on liquid based additive manufacturing machine. For the real time concern the material used should be urethane plastic which is flexible and capable of retaining gas in it. The prototype is a dummy model hence no pressurized gas has been filed in but the real time model can be filed in with nitrogen or some other denser gases which have enough density so that they do not escape out of sole.



Fig. 12: Additive Manufacturing Machine from Objet Eden350V

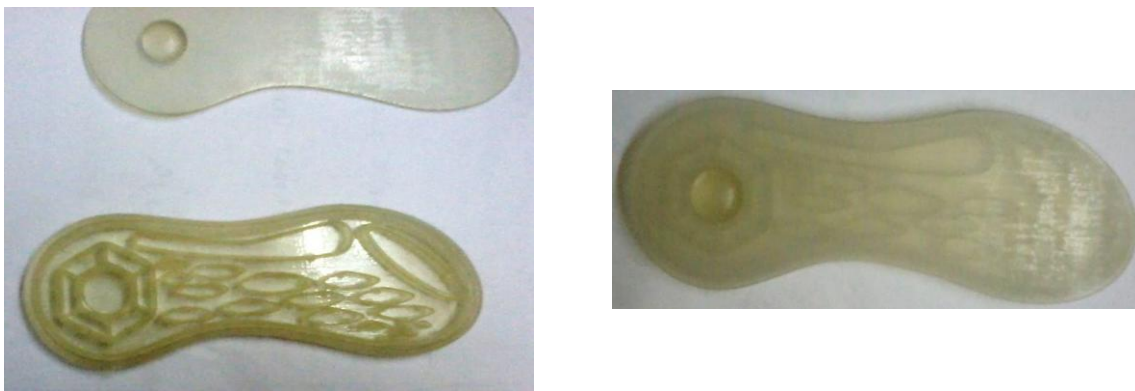

Fig. 13: Prototyped Component

5. Material selection

The material selected for the prototype is TANGO PLUS which is a rubber like material and which uses supporting material wax. The reason for selecting the material is as follows.

5.1. Selection of material

Engineering design draws on tens of thousands of materials and on many hundreds of process to shape, join and finish them. One aspect of optimized design of a product or system is that of selecting, from this vast menu, the materials and processes that best meet the needs of the design, maximizing its performance and minimizing its cost. The problem, still incompletely solved, is that of matching material and process attributes to design requirements. Some of these attributes can be expressed as numbers, like density, flexibility or thermal conductivity; some are Boolean, such as the ability to be recycled; some, like resistance to corrosion, can be expressed only as a ranking (poor, adequate, good, for instance).

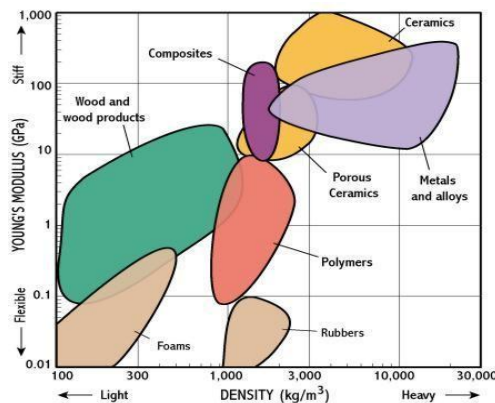

Fig. 14: Ranking Chart Using Material Index

5.2. About tango plus

[12]Tango Plus is a translucent flexible elastomeric material offering an unmatched combination of mechanical properties, setting a new standard in rubber-like performance. At 218%, both Tango Plus and Tango Black Plus have an elongation at break that is more than double that of any other rapid prototyping material available on the market. It is highly resistant to tearing and has a Ross Flex measurement in excess of 150,000.

Tango Black Tango Black and Tango Gray rubber like flexible 3D Modelling materials enable models that closely resemble the "feel" of flexible target products.

Tango Gray Tango Black and Tango Gray enable a realistic rubber/silicon feel, and easily stretch to fit onto other parts. Tango Black plus Tango Black Plus rubber-like material offers exceptional elongation at break, excellent toughness and durability and high resistance to tearing

6. Conclusion

Thus a design of a midsole was finally developed considering human factors arrived through survey as a part of product lifecycle management. The gas used will help to maintain a soft cushion and stiff support to the wearer. Thus a highly comfortable and ergonomically better shoe sole design was achieved; this helped in meeting the customer requirements. To make the design more appealing it is suggested to make it of a transparent material. A further research is required to complete the shoe with a midsole of this kind along with application of advanced materials.

Acknowledgements

The authors heartily acknowledge Mr. K. Hariharan, M.E, (PhD), Research scholar, Department of Manufacturing Engineering, College of Engineering Guindy, Anna University, Chennai-600025 and Mr. Herald Wilson Raja Adroit CAD Solutions Private Limited, Chennai-600083.

References

- [1] Yasunori Sugiyama, Jan 17 1989, U S Patent, Mid sole for sports shoe.
- [2] Cavanagh, P. R. 1980, the running shoe book, Mountain View, CA: Anderson World.
- [3] Ing-Chung Huang, Jun 9 1987, US 4670995 A, Air cushion shoe sole, Clarke, T.E., E.C. Frederick, and C.L. Hamill Jan 1983, The effects of shoe design parameters on rear foot control in running, medicine and science in sports and exercise vol.15, No.5,pp,376-381,1983
- [4] Ravindra S. Goonetilleke, 2003, Designing footwear: back to basics in an effort to design for people, Proceedings of SEAMEC 2003, Kuching,25-31
- [5] GUO Hua, 2010, the new curriculum Reform: Wearing New Shoes to walk on the Old Path.
- [6] Clivia Schubert, Doris Oriwol & Thorsten Sterzing, 2011, Gender and age related requirements of running shoes: a questionnaire on 4501
- [7] runners, Volume 3, Supplement 1
- [8] Xaver Kaelin, Bernhard Segesser & Tanja Wasser, 2011 , Unstable shoes and rehabilitation, Volume 3, Supplement 1
- [9] Zheng Xiu-yuan, LIU Jing-min , 2009 Researches on Sports Shoes and the Development Tendency
- [10] Chua C.K, Leong K.F. and Lim C.S, Rapid prototyping.
- [11] Frank W.Liou, Rapid prototyping and Engineering applications.
- [12] <http://www.objet.eu/3d-printer>.