

# Optimization Approach to Flat Slab Reinforced Concrete Building Frame Design

Sergii Mykytenko<sup>1\*</sup>

<sup>1</sup>Poltava National Technical Yuri Kondratyuk University, Ukraine

\*Corresponding author E-mail: mukutas@gmail.com

## Abstract

In the article it is proposed to use optimization methods for the flat slab reinforced concrete frames design in order to reduce the reinforced steel and concrete costs during the construction. The use of flat slab reinforced concrete frames is a promising direction for providing citizens with affordable housing. It is proposed to implement rational design of flat slab reinforced concrete building frames using the methods of structural-parametric optimization and discrete-continuous mathematical programming. To solve the problem, conditional optimization methods are applied. The algorithm for calculating the frame of a multi-storey building has been developed. The algorithm is implemented by available means and does not require the creation of special computer programs. The author of the article implements a combination of discrete and continuous optimization methods for reinforced concrete structures calculation. This method application allows to design efficient flat slab reinforced concrete frames for the affordable housing construction.

**Key words:** flat slab column conduit, reinforced concrete building frame, affordable housing, structural-parametric optimization.

## 1. Introduction

One of the main problem of affordable housing modern construction is houses cost reduction by their construction complexity reduction, materials cost savings, energy-efficient enclosing structures use. One way to solve this problem is use of advanced building structures. The most common system for housing is a wall system that allows to build houses up to 25 floors in height when bearing walls are crossed. Walls in such a system have functions of fencing and holding vertical loads and simultaneous stiffening diaphragms functions. Such a system is effective in terms of providing building rigidity, stability and bearing capacity, but it is irrational from the standpoint of architectural planning, material consumption and energy saving. Only with a transverse or longitudinal arrangement of the bearing walls, the building individual technical and economic indicators can be improved, but the number of floors, depending on the absence or presence of stiffening diaphragms, is limited to 10 or 17 floors, respectively.

The growth of requirements for energy saving in multi-storey buildings aggravates the contradictions associated with the strength and resistance of wall materials heat transfer, therefore attempts of separating the walls load-bearing and enclosing functions are reasonable. This problem solution is possible with the use of reinforced concrete high-rise frame houses. Such framework elements as columns and rigidity diaphragms are designed only to bear the vertical and horizontal load and non-bearing walls are made of effectively energy-saving materials.

The prototypes of the frame constructive system are framed, braced and braced framed systems. These prototypes can be either beam or girderless.

Beam frames with separate support of plates on girders and girders on columns consoles were not widely used in residential construction, but their prefabricated monolithic systems with

Integrated beam-plate were developed in such systems as Sochi, SARET, RADIUS "Arcos", "KUB"[1], "Kazan XXI" and they were applied in housing construction. Also recently, flat slab frames, consisting of flat slab floors and columns without cantilevering, have become widespread.

## 2. Purpose

In this article, optimization approach to the monolithic flat slab reinforced concrete frames design in order to reduce the costs of reinforcing steel and concrete during their construction is proposed.

## 3. Methodology

Flat slab column conduits (Fig. 1) are the simplest structures consisting of uniform thickness reinforced concrete slabs and constant cross section columns. This design simplifies formwork and concreting; its use is economically efficient where there is no need for arranging suspended ceilings for engineering services. For the first time such slabs were applied in 1940 during houses building in the cities of Newark and Atlantic City (USA) [4]. Then this slab design was widely used in Australia [5]. Today, there are many examples of efficient application of such constructions, both at new housing construction and in the process of reconstruction. Among them, industrial flat slab frame (the system of the "CUBE" type) is standing out in a particularly convincing manner. It has been applied since the late 60s of the previous century, and today it has undergone many modifications in the process of its application for solving the targets of the program on providing people with low cost housing. (Fig. 2)

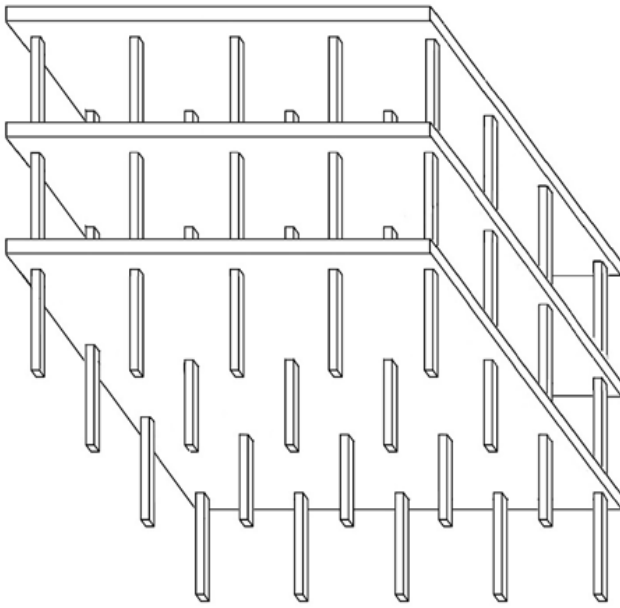

Fig. 1: RC flat slab column conduit

In March, 2008, according to the design of the State Urban Development Design Institute "Miskbudproekt", within the pilot experimental building program, first in Poltava, the advanced "CUBE" system [1] was applied in low cost housing buildings as well as in buildings for other purposes (Fig. 3).

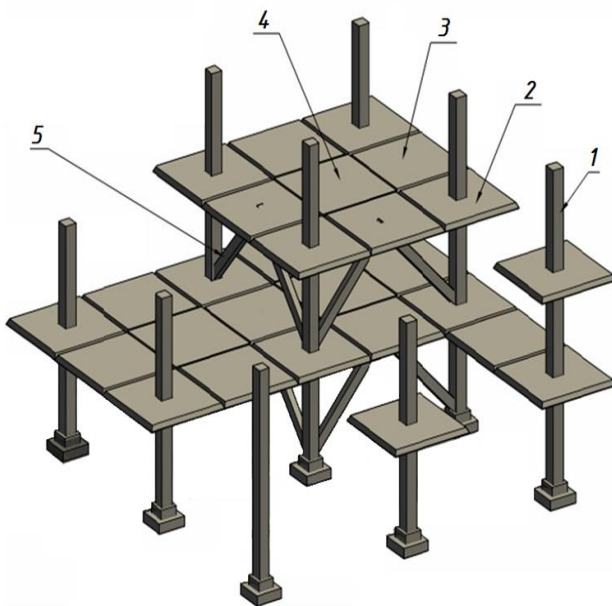

Fig. 2: RC precast flat slab column conduit:

1 – column drops; 2 – intercolumnar plates; 3 – central plates.



Fig. 3: Residential, 16-storeyed house in the city of Poltava

Due to the fact that with flat slab structures, the columns have a constant cross-section, it is easy to connect them with the walls and parting walls between the columns. Therefore, they are convenient for residential buildings and administrative buildings.

When using flat slab frames in houses monolithic construction, the columns location, the spans size, the elements sections dimensions are not strictly regulated, so the search for the optimal values of these parameters is possible.

Optimal design is a targeted choice of design parameters, which enables to get the best result by a certain criterion. To solve such problems, optimization methods are advisable to apply, that makes it possible to consider the influence of various factors simultaneously. Optimization is the process of setting the object in the best condition. Such a process requires a model mathematical model, a target function, and an optimization algorithm (Fig. 4). The objective function sets the requirements for the object. The optimization algorithm should provide the search for the extremum of the objective function. For the development and study of optimization algorithms, mathematical programming methods are used. Optimization tasks can be divided into parametric, structural, and structural-parametric. Today, the problems of parametric optimization or the so-called parametric synthesis are studied better, and methods of structural-parametric optimization are still at the initial stage of development.

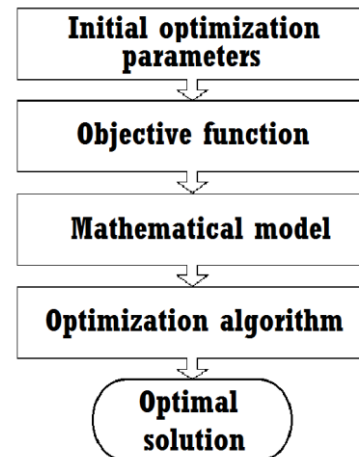
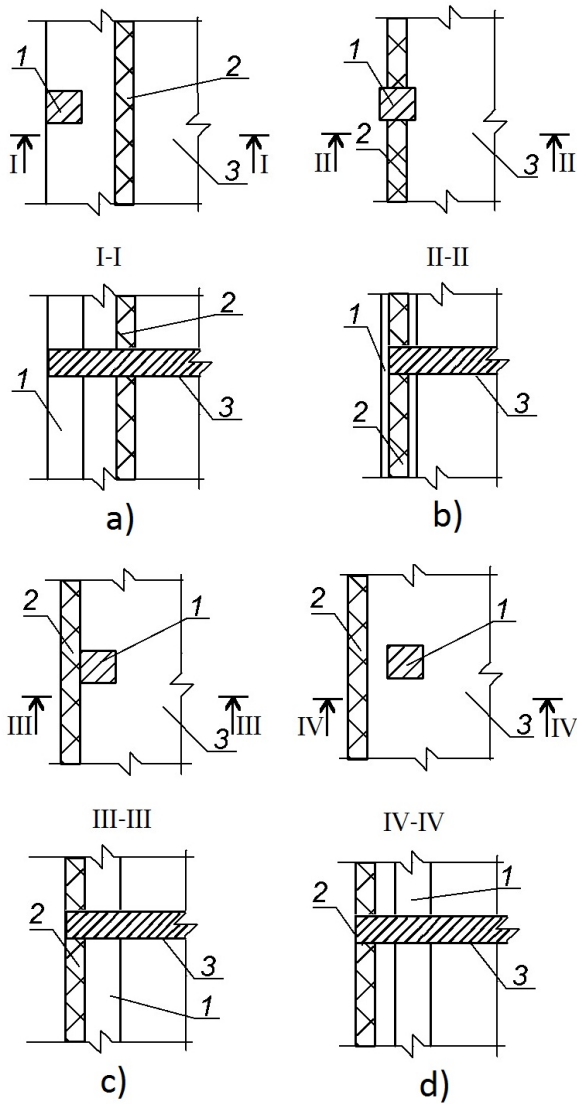

Fig. 3: The structure of the optimization process



**Fig. 4:** Options for the columns placement relative to external walls: a - outside the building; b - in the wall plane; in - near the wall; r-in the middle of the building; 1 - column; 2 - outer wall; 3 - floor slab

The design of external columns or pillars depends on their location relative to the external wall. The column can be located in front of the external wall, within it or inside the building (Fig. 5). The location of the structures in front of the outer wall (Fig. 5a) may be dictated by the requirements: architectural, planning (increase in free floor space), simpler design and execution of external walls, partitions, engineering communications simplified arrangement at the walls, fire protection structures simplification etc. On the other hand, for columns located in front of the outer wall, the design and cladding problem occurs because they perceive large temperature drop compared with the building internal volume, in particular, a cold bridge at the floor slab junction with the outer walls may occur. The columns arrangement in the outer wall plane (Fig. 5, b) is used mainly in massive structures, when the columns are connected to the outer wall masonry.

When the columns are located at the outer wall from its inner side (Fig. 5, c), the outer wall structure is simplified; there are no cold bridges and large temperature drops, however, in this case, complications with partition structures and communications placement may occur. With the columns arrangement inside the building (Fig. 5, d), the floor structure has a console, which allows to reduce bending moments in the floor, the wall structure is more uniform, there are no cold bridges.

## 5. Results

For rational design of buildings flat slab reinforced concrete frames it is proposed to implement the structural-parametric optimization and discrete-continuous mathematical programming methods. Optimization is carried out using mathematical programming algorithms. In the process of structural-parametric optimization, the elements parameters are included in the frame and its structure change.

The optimization methods application to the solution of the flat slab ceilings cost reducing is given in the following papers [6-8]. The authors used special algorithms and developed computer programs.

The problem is to design girderless flat slab floor construction of the minimum cost for a building with sizes  $B \times L$ . The concrete and reinforcement costs depend on the spans number  $n_x$ ,  $n_y$  and size  $l_x$ ,  $l_y$ , the slab thickness  $h_s$ , the columns supporting the ceiling number (Fig. 6).

The objective function is the reinforcement and concrete cost sum for the entire frame

$$C = (BLh_s + h_c^2 H_F n_c) C_c + 7,85 C_s \sum_{i=1}^m V_{si}, \quad (1)$$

where  $h_c$  – column cross section height;  $H_F$  – floor height;  $n_c$  – total number of columns in the building;  $C_c$  – concrete price per cubic meter;  $C_s$  – reinforcement price per tonne;  $V_{si}$  is the reinforcement volume for slab individual sections

$$\begin{cases} V_{s1} = A_{sx1} l_{sx1} l_y (n_y + 1) \\ V_{s2} = A_{sx2} l_{sx2} l_y n_y \\ V_{s3} = 0,5 A_{sx3} l_{sx3} l_y n_x (n_y + 1) \\ V_{s4} = 0,5 A_{sx4} l_{sx4} l_y n_x n_y \\ V_{s5} = 0,5 A_{sx5} l_{sx5} l_y (n_x - 1) (n_y + 1) \\ V_{s6} = 0,5 A_{sx6} l_{sx6} l_y (n_x - 1) n_y \\ V_{s7} = A_{sy1} l_{sy1} l_x (n_x + 1) \\ V_{s8} = A_{sy2} l_{sy2} l_x n_x \\ V_{s9} = 0,5 A_{sy3} l_{sy3} l_x n_y (n_x + 1) \\ V_{s10} = 0,5 A_{sy4} l_{sy4} l_x n_y n_x \\ V_{s11} = 0,5 A_{sy5} l_{sy5} l_x (n_y - 1) (n_x + 1) \\ V_{s12} = 0,5 A_{sy6} l_{sy6} l_x (n_y - 1) n_x \\ V_{s13} = A_{sc} H \Pi n_c \end{cases} \quad (2)$$

Figure 7 shows the results of objective function (1) analysis for the different reinforcement percentage.

It seems reasonable to take kinematic limit equilibrium method as a basis of calculation [4], which is generally described by the balance between the virtual work of external and internal efforts in the possible relevant movements in the direction of the load  $q$ ,  $P_j$  and effort  $M_i$ :

$$\int_A y_q \cdot q \cdot dA + \sum_{j=1}^k P_j y_j = \sum_{i=1}^n M_i \cdot \varphi_i \cdot l_i, \quad (3)$$

where  $y_q$  - plate's moving due to the load;  $q$ ,  $y_i$  - plate's moving under the load  $P_j$ ;  $M_i$  – moment in the  $i$ - linear plastic hinge per a unit of its length;  $\varphi_i$  - angle of the disc turn in the  $i$ - linear plastic

hinge;  $l_i$  - length of the  $i$ - plastic-hinge;  $n$  - the number of linear plastic hinges sites under consideration.

The reinforcement areas  $A_{si}$  are determined for each section according to the recommendations given in [2].

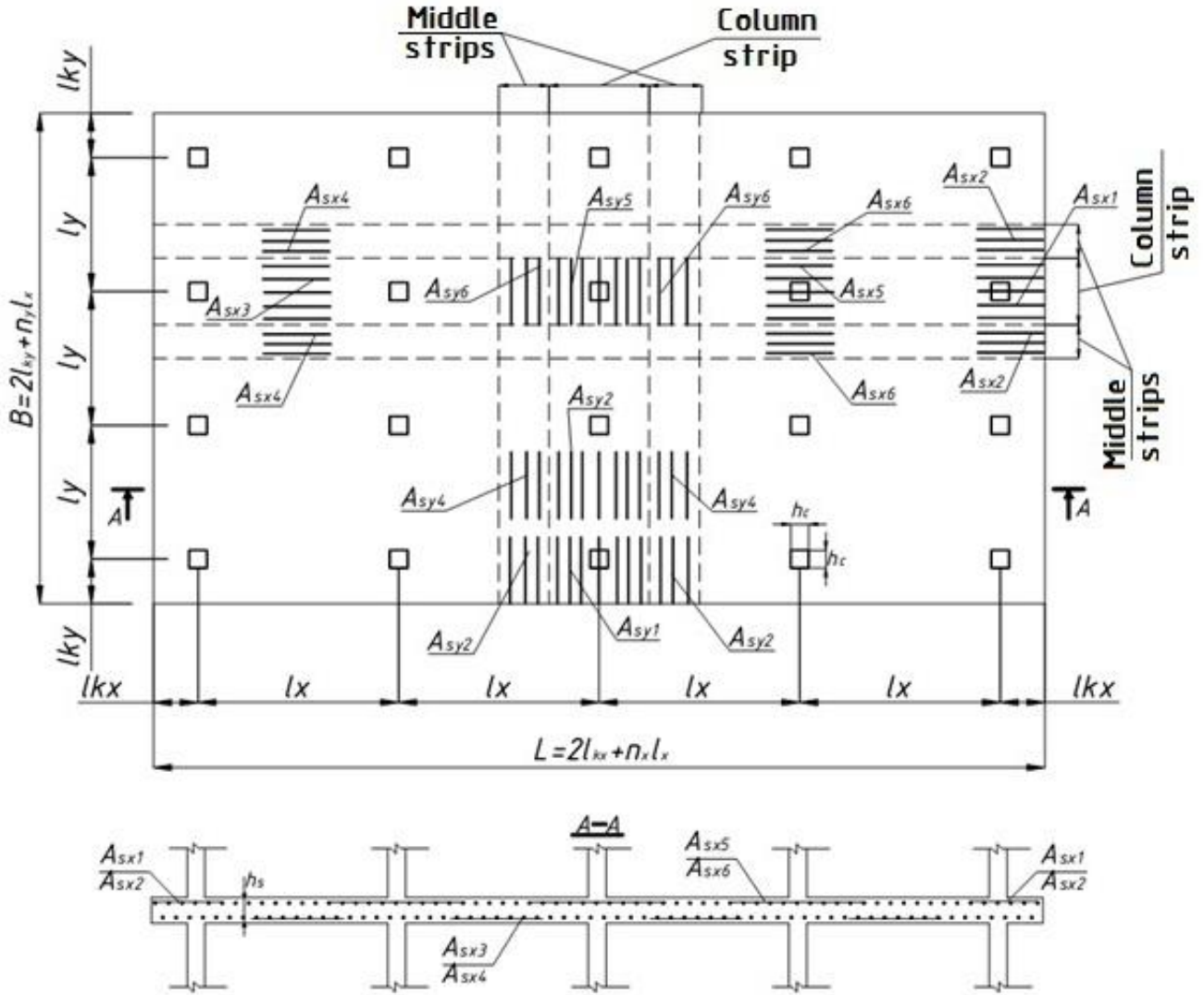

Fig. 6: Variable design parameters of the monolithic flat slab frame

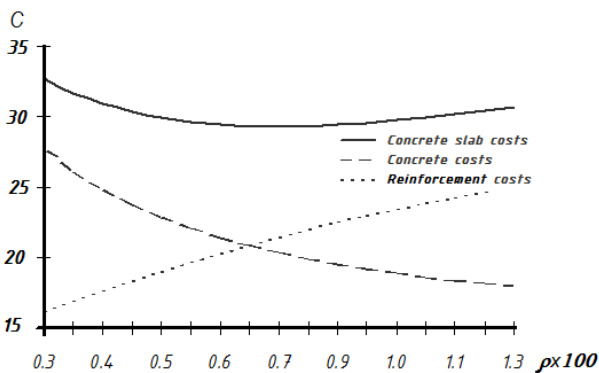

Fig. 7: The costs of reinforced concrete overlap  $C$  depending on the percentage of reinforcement  $\rho$

The reinforcement areas  $A_{si}$  are determined for each section according to the recommendations given in [2].

The variable parameters  $l_x$  and  $l_y$  are continuous values,  $n_x$  and  $n_y$  - are discrete values. It is proposed to take overlap spans

$l_x$  and  $l_y$  as optimization parameters, while other components of the objective function depend on them functionally. The number of spans in the direction  $L$  and  $B$  is determined by dependencies

$$\begin{cases} n_x = \lfloor L/l_x \rfloor \\ n_y = \lfloor B/l_y \rfloor \end{cases}, \tag{4}$$

where the formula  $\lfloor \cdot \rfloor$  is the integer part of the fraction.

The columns number is determined by the formula

$$n_c = (n_x + 1)(n_y + 1). \tag{5}$$

In the process of calculating it is necessary to check compliance with the conditions of crack resistance and plate deformability.

$$\begin{cases} a_{crc} \leq [a_{crc}] \\ f \leq [f] \end{cases} \quad (6)$$

Condition (6) is a limitation in the conditional optimization algorithm for the objective function (1).

To solve the optimization problem, the Solver program built into the MS Excel spreadsheet was used. The conditional optimization procedure in Excel 2007 is called by the "Data / Analysis / Search for a solution" command. The result of the optimization problem solving is the parameters values  $A_{si}$ ,  $l_x$ ,  $l_y$ ,  $n_x$  and  $n_y$  for which the objective function (1) is minimal.

## 6. Conclusions

1. Based on the methods of conditional optimization, algorithms for rational design of building flat slab reinforced concrete frames are developed.
2. The developed algorithm makes it possible to determine rational parameters of elements that are part of framework using structural-parametric optimization methods.
3. To implement the algorithm, the available Solver program as part of the MS Excel spreadsheet processor was applied.

## References

- [1] Onyshchenko V, Pavlikov A, Mykytenko S (2016), Implementation Of Flat Slab Column Reinforced Concrete Frames In Low Cost Housing Construction, *Inzynieria Bezpieczenstwa Obiektow Antropogenicznych*, №3, pp. 29–33.
- [2] Pohribnyi V, Dovzhenko O, Maliovana O (2018), The Ideal Plasticity Theory Usage Peculiarities to Concrete and Reinforced Concrete. *International Journal of Engineering & Technology*, Vol. 7(3.2), pp: 19–26, <http://dx.doi.org/10.14419/ijet.v7i3.2.14369>.
- [3] Pavlikov A, Mykytenko S, Hasenko A (2018), Effective structural system for the affordable housing construction, *International Journal of Engineering & Technology*, Vol. 7(3.2), pp: 291–298. <http://dx.doi.org/10.14419/ijet.v7i3.2.14422>.
- [4] Di Stasio J (1941), Flat Plate Rigid Frame Design Of Low Cost Housing Projects In Newark And Atlantic City. *N. J. Proc. American Concrete Institute*, Vol. 37, pp. 309–324.
- [5] Blakey FA (1965), Towards an Australian structural form – the flat plate. *Architecture in Australia*, Vol. 54, pp. 115–127.
- [6] Hadi MN, Sharafi P, Teh LH (2012), A new formulation for the geometric layout optimisation of flat slab floor systems *Australasian Structural Engineering Conference (ASEC 2012)* pp. 1-8, available online: <http://ro.uow.edu.au/cgi/viewcontent.cgi?article=3014&context=eispapers>, last visit: 22.09. 2018.
- [7] Patil KS, Gore NG, Salunke PJ (2014), Minimum Cost Design of Reinforced Concrete Flat Slab. *International Journal of Recent Technology and Engineering (IJRTE)*, Vol. 2, №6, pp.78-80.
- [8] Sahab MG (2008), Sensitivity of the optimum design of reinforced concrete flat slab buildings to the unit cost components and characteristic material strengths. *Asian Journal Of Civil Engineering (Building And Housing)* Vol. 9, № 5, pp.487-503.
- [9] Zandi Y, Naziri R, Hamedani R (2013) Effect of Layout and Size Optimization Conditions in Architectural Design of Reinforced Concrete Flat Slab Buildings. *Bulletin of Environment, Pharmacology and Life Sciences*, Vol 2 (5), pp. 62-68.
- [10] Kochkarev, D., & Galinska, T. (2017). Calculation methodology of reinforced concrete elements based on calculated resistance of reinforced concrete. Paper presented at the *MATEC Web of Conferences*, , 116 <https://doi.org/10.1051/mateconf/201711602020>
- [11] Piskunov, V. G., Goryk, A. V., & Cherednikov, V. N. (2000). Modeling of transverse shears of piecewise homogeneous composite bars using an iterative process with account of tangential loads. 1. construction of a model. *Mechanics of Composite Materials*, 36(4), 287-296. doi:10.1007/BF02262807
- [12] Piskunov, V. G., Gorik, A. V., & Cherednikov, V. N. (2000). Modeling of transverse shears of piecewise homogeneous composite bars using an iterative process with account of tangential loads 2. resolving equations and results. *Mechanics of Composite Materials*, 36(6), 445-452. <https://doi.org/10.1023/A:1006798314569>