

# A novel semantic medical access monitoring system for e-health applications using internet of medical things

Lahari Vyshnavi Bommasani <sup>1\*</sup>, Erukala Suresh Babu <sup>2</sup>, Sasank Aluri <sup>3</sup>

<sup>1</sup> Computer Science and Engineering, Koneru Lakshmaiah Educational Foundations

<sup>2</sup> Professor, Computer Science and Engineering, Koneru Lakshmaiah Educational Foundations

<sup>3</sup> Computer Science and Engineering, Koneru Lakshmaiah Educational Foundations

\*Corresponding author E-mail: [laharivyshnavi9@gmail.com](mailto:laharivyshnavi9@gmail.com)

## Abstract

Internet of things can connect various smart devices together by using Internet. It also provides data interoperability methods for application purpose. We have proposed an IOT -based framework for emergency medical services to show how to collect, integrate, and interoperate IOT data flexibly and also to support medical emergency services. By the development of IOT technologies, we can use medical sensors to monitor patient's health even without the presence of doctor. We came up with a outline of Semantic Medical Monitoring Framework with the help of cloud based IOT techniques. IOT health sensors will accept the massive data from the patient for every 6sec. All these data will be stored in the cloud and medical data will be connected to a medical rule engine through a web service called "THINK SPEAK". It also permits supervision of patient by remote centers and personal platforms such as mobiles, tablets. Regarding Hardware it provides a gateway and personal clinical devices used for continuous wireless transmission of monitored data of the patient.

**Keywords:** Clinical Devices; Framework; Gateway; Medical Rule Engine; Semantic; Think Speak; Wireless Transmission.

## 1. Introduction

The Internet of things is playing a major role in the field mankind industries and also in the area of engineering. IOT has a wide range of network products, systems and sensors, which will take the advantage of development in network interconnections, computing and also in electronics to provide new abilities to the products. The huge implementation of IOT devices has many aspects like Connectivity, Dynamic nature, Sensing ability, Heterogeneity and Security that makes products more efficient. Even though a lot of conferences, reports and articles discussed regarding the impacts of " IOT Revolution " in [1] therefore business models are worried about the data interoperability, privacy and security of the IOT devices. However, IOT have a lot of issues and challenges that needs to be taken care to get the potential benefits. Development of IOT devices enabled a lot of applications such as Internet-enabled products, home automations, and energy management services and also for the implementation of smart cities with the help of sensors. IOT networked sensors even provides distribution of the massive information comes from industry, agriculture and power production. By recent studies IOT devices are now even capable of providing health services to the people even without the supervision of the doctor by this many villages and elderly people get benefited. In this paper we have proposed a framework for Semantic Medical Access (SMA) in [2]. IOT-based healthcare developers are paying close attention towards medical semantics by calling a separate service called Semantic Medical Access. SMA is a patient monitoring system involved with medical rule engines to understand large amounts of sensor data. However, SMA is failed to integrate the medical data this paper helps to avoid such problems in [3], [4]. Taking all the above things into consideration we have proposed a new framework in semantic

medical access, which is involved with continuous data tracking system with alert mechanisms and the framework has a login, which is known only to the doctor.

## 2. Related work

This section presents the related work of various e-health care application in the literature. In [1] S.M.Riazul islam et.al present a paper regarding the use of semantic medical access can share a large amounts of medical data by using different ontologies. Medical semantics have received a wide attention by IOT based health care applications. That paper has discussed issues of semantic medical access in context with IOT environment. Boyi Xu et.al [2] proposed a lot of medical sensors have come into existence to monitor patients data and that paper ever saying how to organize medical sensor data in database. Antonio J Jara et.al [3] explained about the end to end framework to monitor a person and it also discuss about a critical issue for data mining, trending and analysis which plays a major role in mobile e-health monitoring system in that paper. Xueqin Jia et.al [4] proposed a framework regarding E-health monitoring ecosystem and current E-health monitoring market segments in 3 different models. In that paper main objective is to implement a key technology is used to support for service support platform. While coming to Vittorio Miori et.al [5] tells about how embedded system are used in IOT and it also explained how to analyze and collect the data from the health sensors they have implemented a new ontologies that automatically take distributed environment context information in that paper. In Ranchel L [6] et.al discussed about the issues in latest health data standards are related to quality, cost and continuous care for patient's safety and it also tells about requirements and motivations for standardized data of clinical research in their paper. Lei Wang

et.al explained process regarding development of chips for body sensors which are completely evaluated and tested before it comes to real world it needs to satisfy all the typical system requirements in his paper. Charles L. Forgy [7] paper he written about a framework for basic concepts of algorithm and presents the object and pattern representations that are correct for a algorithm. A.Dohr et.al [8] proposed a model to establish in between things and internet took place and what kind of techniques are used in health sector to implement E-Health Monitoring system. That technique is used to Implement E-Health Monitoring System is KIT technology is used to connect the smart objects. Rumen Kyusakov [9] explained about the Simple object access protocol it provides web services without the using any gateways and also tells about the integration of systems with wireless sensor nodes where we can do research further by help of that paper. Nuno Pereira et.al [10] also proposed a modal for the acceptance of data from the channel to the node even without calling any protocols. The framework proposed in that paper is even collision free and they applied that framework on automotive electronics. In future they want there is a scope of long-range communications. Eonastantinos kakousis, et.al [12] made a survey to evaluate software approaches and modify them by deploying ubiquitous computing and mobile environments. By that we can attain adaptive mobile systems. Shanchag Li, et.al [13] have proposed a platform which can provide access control functionalities in any framework by using that framework it can be able provide a secured access of cloud to the users and it can even control the number of users to use the cloud space. Chenquang He, et.al [14] has proposed a new framework for the private cloud platform, which will have 6 different layers to store the large amount of unorganized medical data in the cloud. In that paper the modal which they have proposed is having most efficient features to access the cloud data. Ruman kyusakove, et.al [15] also proposed a paper to analyze the Simple Object Access Protocol with different approaches. Those approaches are even examined on highly structured XML descriptions. Zhibo pang, et.al [16] has designed a paper regarding home healthcare services by integration of hardware and software architecture they has implemented a prototype. That prototype will be helpful to the patient and the stakeholders to understand the patient's condition with the help of these approach. Bogdon M et.al [17] has presented a approach which doesn't require a special instrument to pump the oil from the induction motor this application of this technology could lead to effective monitoring of the oil wells. Li Da Xu [18] reviewed about research in IOT key technologies in industries and identified the challenges of the present technologies and applied them on wireless sensor networks by combining IOT and cloud. Gusy le et.al [19] has done the research in the area of GIS to construct a stray prevent system for old persons suffering from dementia without interfering with their activities of daily livings this can be applied in Health GIS to monitor the patient's. Jianchu Yao et.al [20] investigated the feasibility of applying the original hospital standards with multi sensor monitoring systems designed for home healthcare by that application it can attain home health monitoring systems.

### 3. Overview of various e-health applications and its services

This section presents overview of various E-Health Applications and its services in which IOT are able to provide various Health monitoring services and even it has the potential to build several other applications but the general protocols and services, which needs to be improved in [1]. Some of the various types of E-Health services and applications from the Figure (1) are Indirect Emergency Services: Many of the emergency services are due to health issues. Indirect emergency services will be helpful to record the condition of the patient during the adverse weather conditions and even it has the actions, which can be used after the accidents. Embedded Gateway services: This service is used to connect the sensors, which are connected to the patients with Internet of the medical equipment, and it will also deploy features near the gateway of medical sensors. Medication Management system: Improper medication can be a serious threat to the people around the world. So this medication management system has provided an effective packing system for the medicines this packing method will be guided and controlled by the wireless protocol. Oxygen monitoring services: Pulse oximeter is used to continuously monitor the patient with combination of IOT. Pulse oximeter is very cheap and portable so that patient can be able to easily carry it to anywhere. Wearable Device services: Different sensors has come into existence to provide medical services Wearable device will give the same services with the help of IOT. But wearable devices need to be integrated with the IOT gateways. Children's Health Monitoring services: By these services one can be able to understand the kid's mental behavior by M-Health services. It will even motivate and educate the children to acquire good behavior and make them eat nutritious food habits with the help of the Children's health monitoring services. Community health services: These services are most likely to control the rural municipalities and pollution in the residential areas. Community health services will try to control the diseases caused germs, which are spreads, by the drainage systems and dustbins et.al. These are the different services provided by the E-Health monitoring system. IOT even provides different applications of the health monitoring system such as, ECG Monitoring system: The electrical activity of the heart will be recorded by the heartbeat sensors which allows us to monitor the patient continuously with the help of IOT. Body temperature monitoring system: The patient's body temperature can be monitored continuous with the help temperature sensor, which is attached to the patient's body and by using IOT devices we will monitor the patient all the time. Monitoring Glucose level: This type of monitoring is mainly useful for the diabetic people because their level of glucose content in their blood usually changes from period to period. To do this monitoring patient will be equipped with sensors which are integrated by IOT. In general IOT opts Semantic Medical access to provide all these services and applications of E-Health monitoring system.

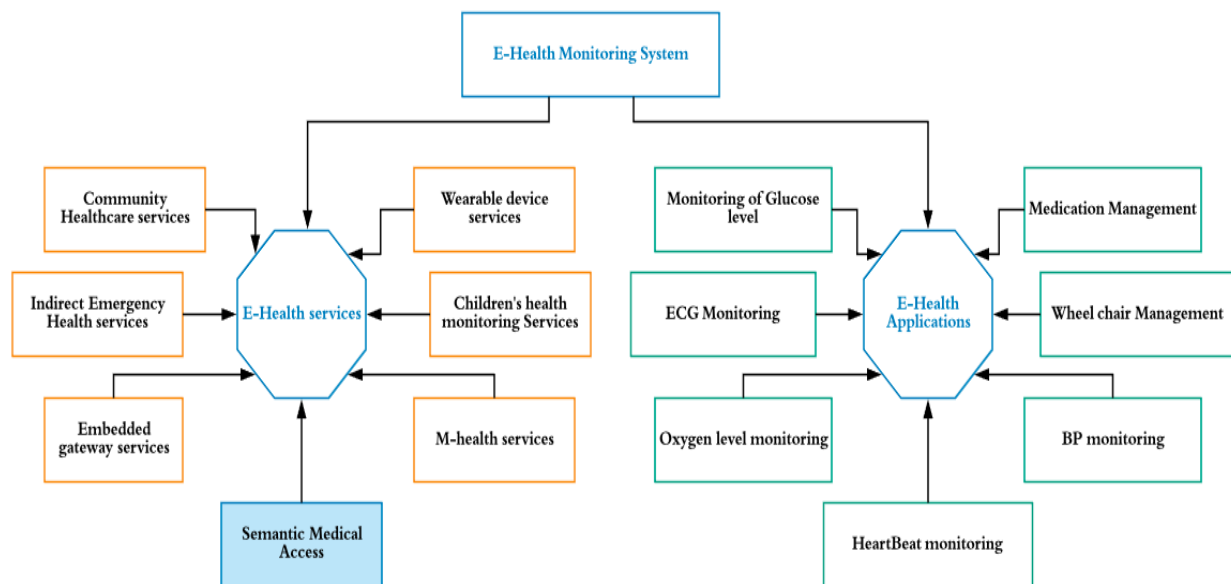

Fig. 1: Block Diagram of Applications and Services of the E-Health Monitoring System.

#### 4. Overview of semantic medical access

Semantic medical access provides a framework that can help to identify the medical condition of the patient. Semantics and ontologies are used in SMA [2], [3], [4] to share large amounts of medical information from sensors which are fixed to the patients. Medical rule engine helps to validate the huge amount of sensor information that is saved in the cloud. Different patterns like Figure (2) are used to collect, integrate and validate the sensor data to monitor the patients health condition. The advantages of using semantic medical access are we can be able track the patients pulse, body temperature and other particulars. SMA also collects the data in very organized manner with the help of data analytics. SMA enabled the Re-engineering of medical processes by taking IOT as a platform. By using different resources patient health can be monitored even without the presence of the Doctor with a perfect framework. SMA can help to transmit large amount of patient's sensor data at once to provide a quality in patient care. The disadvantages of semantic medical access are there is no correct information regarding the framework which are used to collect, integrate and to validate the data. It is difficult to find the responder to analyze the patient's. New frameworks need to be designed in [5]. We need to resolve a lot of security issues in order save the data from the attackers. Taking all the above things into consideration we have proposed a new framework in semantic medical access. Which is involved with continuous data tracking system with alert mechanisms and the framework has a login which is known only to the doctor.

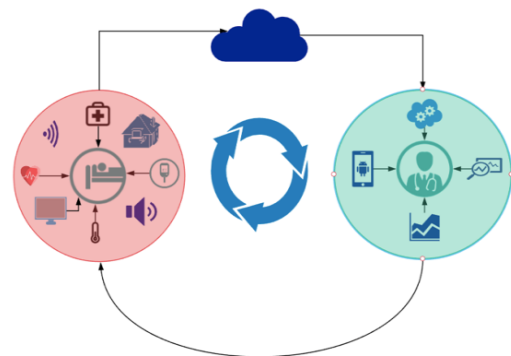

Fig. 2: Flow Diagram of Semantic Medical Access.

#### 5. Proposed model for semantic medical access

Keeping in mind the end goal to gather the client data that mirror its movement and medicinal signs, different sensors are required. These sensors are lightweight with a specific end goal to be wearable. In Figure (3) a heartbeat oximeter sensor is utilized to quantify the measure of oxygen broke down in the client's blood, in view of the identification of Hemoglobin and Deoxyhemoglobin. Such a sensor is valuable in the circumstance in which the client's oxygenation is unsteady, and in requires for supplemental oxygen or even escalated mind. An electrocardiogram (ECG) sensor is used to acquire a side arrangement of cardiovascular data, for example, the rate and beat of the heart, the examples of unusual electric movement that may incline the client to strange cardiovascular beat unsettling influences, and how the heart is put inside the chest]pit. Moreover, the ECG sensor gives confirmations of harms that jump out at various parts of the heart muscle, any intensely disabled blood stream to the heart muscle, and expanded thickness of the heart muscle. A nasal/oral wind stream sensor is utilized to quantify the breathing rate of the client to decide if he or she needs respiratory help. A temperature sensor is utilized to gauge the temperature of any piece of the body, and can be moved effortlessly keeping in mind the end goal to be set over the body part where temperature estimation is required. Not with standing the above medicinal sensor that catch the client's wellbeing signs, light what's more, fall location sensors are additionally utilized. The light sensor gives the data that can enable the client to change his/her feeling light, in order to help him/her explore around effortlessly. For instance, when the atmosphere light reductions, readings from this sensor can be utilized to turn on additional lights. The fall identification sensor is an accelerometer that is

used to decide if the client has fallen suddenly, with the end goal that notices signs can be produced to give the required care. In the

below Table (1) you can see the parameters, which we have used in our model.

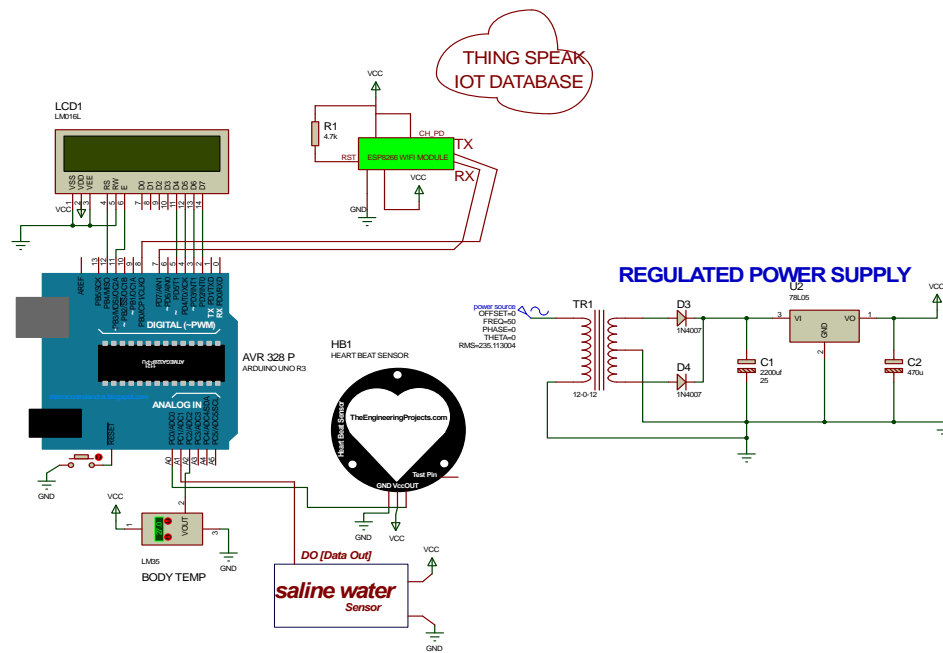

Fig. 3: Proposed Prototype for Schematic Medical Access.

Table 1: Parameters Used in the Proposed Prototype of Semantic Medical Access.

Components	Block Diagrams of the components	Description of the components
Power Supply		We are using regulating power supply to the Aurdino.
Aurdino		A microcontroller is a PC control framework on a solitary chip. Here we are taking Aurdino to provide platform to the medical sensors and we have loaded instructions to the Aurdino for the better performance of the sensors.
LCD		LCD Display is used for the display of patient’s data while monitoring.
ESP8266		ESP8266 is used for store the data of the sensors in the cloud, which helps the doctor to evaluate the patient continuously, even without his presence.
Heartbeat Sensor		It is basically used for monitoring patient’s heartbeat. The sensor clip on to the fingertip that is connect- ed to the Aurdino by the help of cables.



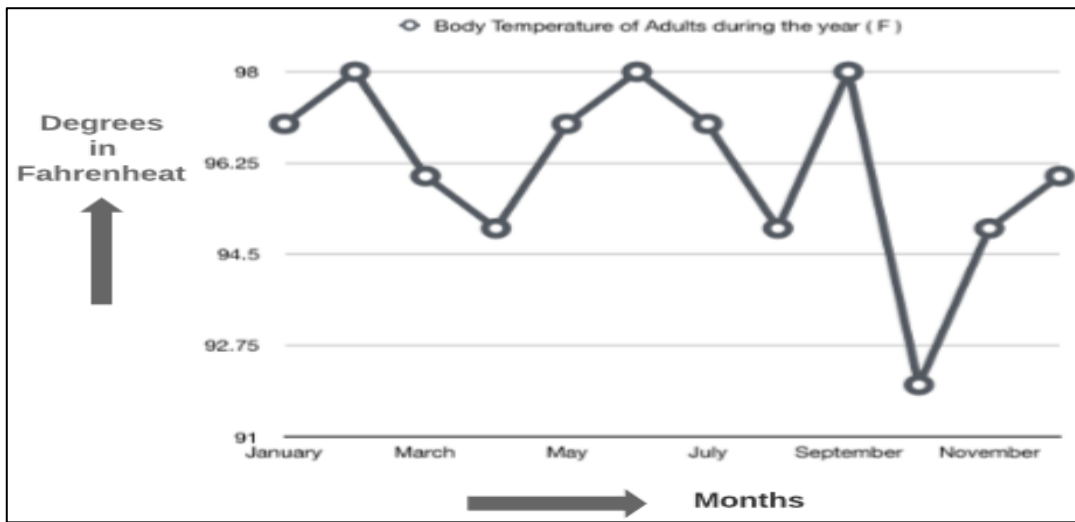

Fig. 4.2: Detection of Adults Body Temperature through Out the Year.

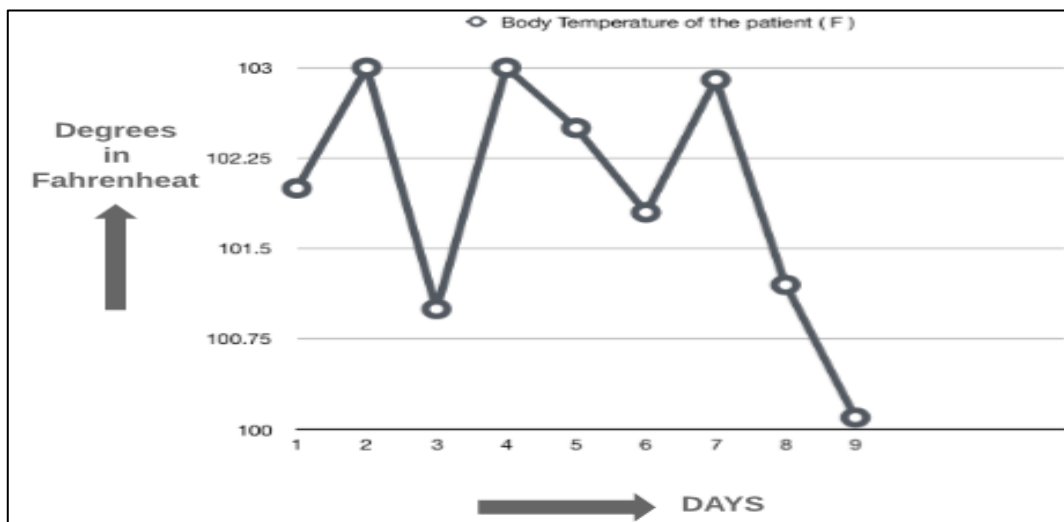

Fig. 4.3: Decreasing of Patient's Body Temperature by Proper Medication.

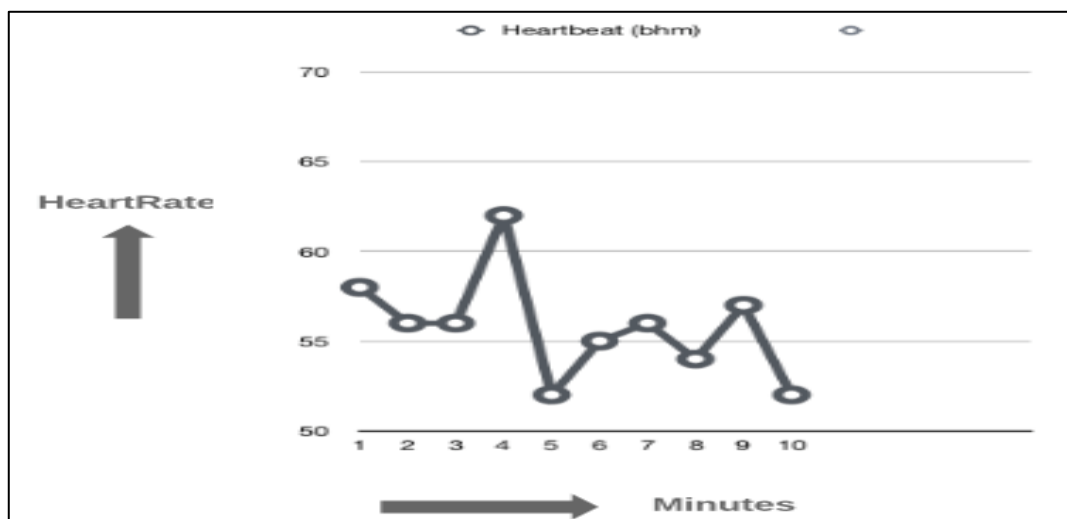

Fig. 5.1: Patient's Heartbeat Monitoring for Every Minute.

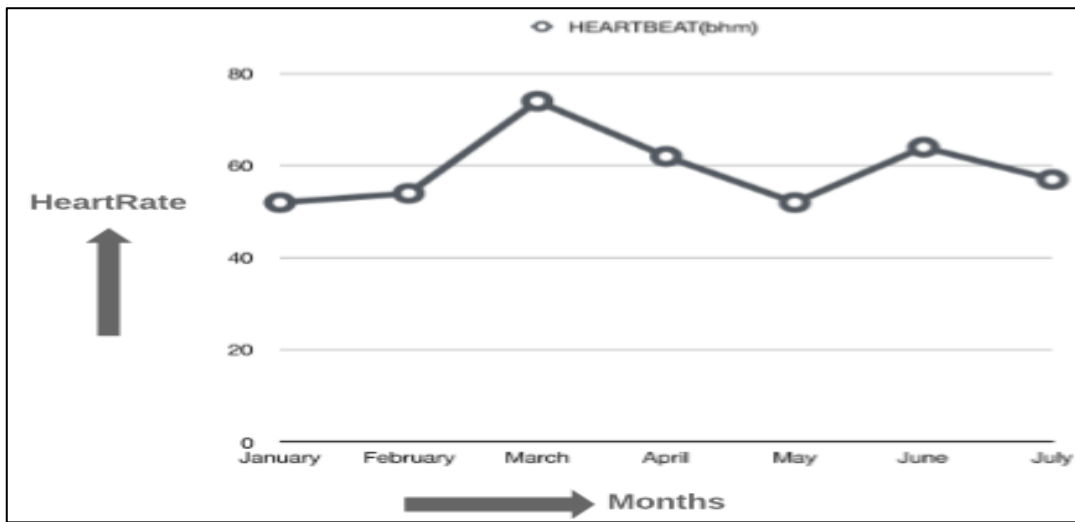

Fig. 5.2: Coma Patient's Heartbeat Monitoring.

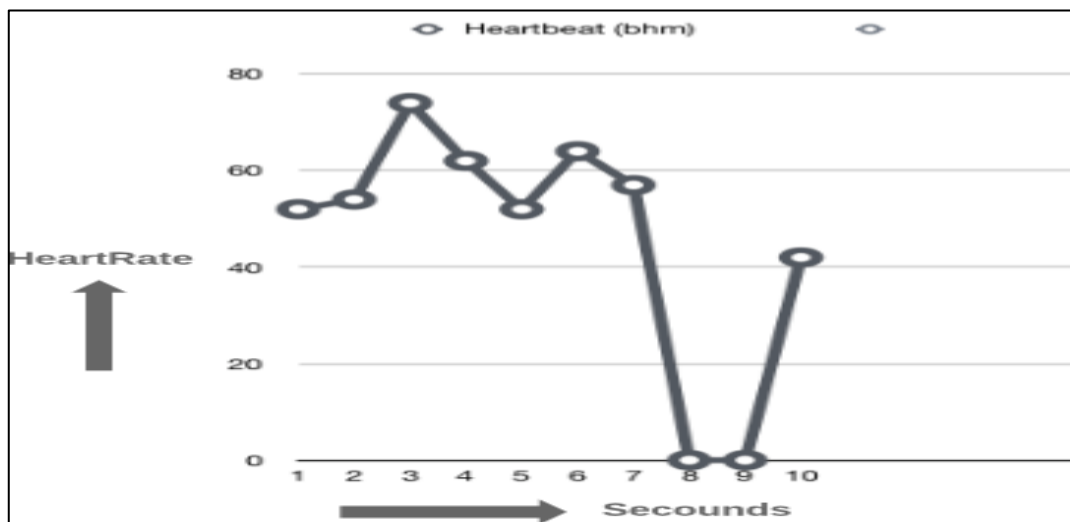

Fig. 5.3: Recovering of the Patient from Stroke.

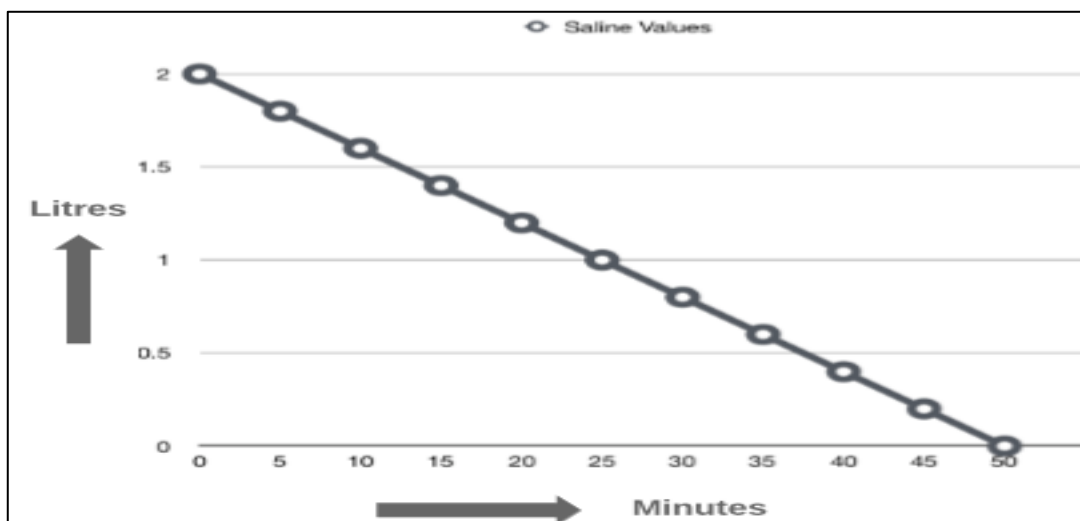

Fig. 3: Patient's Saline State.

### 7. Conclusion

In this paper, we have proposed a prototype for Semantic Medical Access to detect the patient's condition from home. We have illustrated the primary parts of the proposed model and clarified their usage and points of interest. We have constructed a prototype to show the distinctive execution parts of the proposed Model. The

preparatory execution assessment has shown the proficiency of the proposed framework – in spite of being ease one. This makes the proposed framework a decent applicant for Semantic Medical Access. Our future work will incorporate how to secure the Semantic Medical Access network from third party invasions while monitoring the patient.



## References

- [1] S.M.Riazul Islam Et.Al,"The Internet of Things for Health Care: A Comprehensive Survey in Digital Object Identifier", *Ieee Transaction On Industrial Informatics*, Vol.10, No.2 May2014, Available Online: [Http://Ieeexplore.Ieee.Org/Document/7113786](http://ieeexplore.ieee.org/document/7113786).
- [2] Boyi Xu, Et.Al,"Ubiquitous Data Accessing Method In Iot-Based Information System For Emergency Medical Services", *Ieee Transaction On Industrial Informatics*, Vol.10, No.2, May 2014, Available Online: [Http://Ieeexplore.Ieee.Org/Document/6742577](http://ieeexplore.ieee.org/document/6742577).
- [3] Antonio J Jara,Et.Al, "Interconnection Framework For Mhealth And Remote Monitoring Based On The Internet Of Things",2012 *Ieee 14<sup>th</sup> International Conference On E-Health Networking, Applications And Services(Healthcom)*,Available Online: [Http://Ieeexplore.Ieee.Org/Document/6585881](http://ieeexplore.ieee.org/document/6585881).
- [4] Xueqin Jia,Et.Al, "Technical Models And Key Technologies Of E-Health Monitoring",*Ieee Journal On Selected Areas In Communication/Supplement*, Vol.31, No.9, September 2013, Available Online: [Http://Ieeexplore.Ieee.Org/Document/6380059](http://ieeexplore.ieee.org/document/6380059).
- [5] Vittorio Miori Et.Al,"Anticipating Health Hazards Through An Ontology-Based, Iot Domotic Enviroment", *2012 Sixth International Conference On Innovative Mobile And Internet Services In Ubiquitous Computing*,Available Online: [Https://Ieeexplore.Ieee.Org/Document/6296947](https://ieeexplore.ieee.org/document/6296947).
- [6] [6] In Ranchel L,Et.Al,"Data Standards In Clinical Research:Gaps,Overlaps,Challenges And Future Directions",*Journal Of The American Medical Informatics Association* Vol.14, No.6, November/December 2007,Availble Online : [Https://Www.Ncbi.Nlm.Nih.Gov/Pubmed/17712081](https://www.ncbi.nlm.nih.gov/pubmed/17712081).
- [7] Charles L Forgy,"Rete: A Fast Alogorithm For The Many Patterns In Many Object Pattern Match Problem",*Department Of Computer Science, Carnegie-Melleon University, Pittsburgh,Pa15213,U.S.A*, Available Online : [Https://Www.Sciencedirect.Com/Science/Article/Pii/000437028900200](https://www.sciencedirect.com/science/article/pii/000437028900200).
- [8] A.Dohr Et.At,"The Internet Of Things For Ambient Assisted Living", 2010 Seventh International Conference On Information Technology, Year: 2010, Available Online: [Https://Ieeexplore.Ieee.Org/Document/5501633](https://ieeexplore.ieee.org/document/5501633).
- [9] Ruman Kyusakove Et.Al,"Integration Of Wireless Sensor and Acutator Nodes with It Infrastructure Using Service-Oriented Architecture", *Ieee Transaction On Industrial Informatics*, Vol.9, No.1, February 2013, Available Online: [Https://Ieeexplore.Ieee.Org/Document/6198333](https://ieeexplore.ieee.org/document/6198333).
- [10] Nuno Pereira Et.Al," A Department Protocol For Wireless Medium Access", *Ieee Transaction On Industrial Informatics*, Vol.3, No.2, May 2007, Available Online:[Https://Ieeexplore.Ieee.Org/Document/4214854](https://ieeexplore.ieee.org/document/4214854). <https://doi.org/10.1109/TII.2007.898461>.
- [11] Eonastantinos Kakoyusis Et.Al,"A Survey Of Software Adaptation In Mobile And Ubiquitous Computing", *Department Of Computer Science, University Of Cyprus,Nicosia,1678,Cyprus*,Available Online: [Https://Www.Tandfonline.Com/Doi/Abs/10.1080/17517575.2010.509814](https://www.tandfonline.com/doi/abs/10.1080/17517575.2010.509814).
- [12] Schanchag Li Et.Al,"Integration Of Hybrid Wireless Networks In Cloud Services Oriented Enterprise Information Systems", *Institute Of Biomedical Engineering, Xi'an Jiaotong University,Xi'an,China*, Available Online : [Https://Www.Tandfonline.Com/Doi/Abs/10.108017517575.2011.654266](https://www.tandfonline.com/doi/abs/10.108017517575.2011.654266).
- [13] Chenquang He Et.Al,"Towards Ubiquitopus Healthcare Services with A Novel Efficient Cloud Platform", *Ieee Transaction On Biomedical Engineering*, Vol.9, No.1, January 2013, Available Online: [Https://Ieeexplore.Ieee.Org/Document/6324392](https://ieeexplore.ieee.org/document/6324392).
- [14] Ruman Kyusakove Et.Al,"Integration Of Wireless Sensors and Actuator Nodes with It Infrastructure Using Service-Oriented Architecture", *Ieee Transaction On Industrial Informatics*, Vol.9, No.1, February 2013, Available Online: [Https://Ieeexplore.Ieee.Or/Document/6198333](https://ieeexplore.ieee.org/document/6198333).
- [15] Zhibo Pang,Et.Al,"Design Of A Terminal Solution For Integration Of In-Home Health Care Devices And Services Towards The Internet Of Things", *Institute Of Biomedical Engineering, December 2014*, Available Online : [Https://Www.Tandfonline.Com/Doi/Abs/10.1080/17517575.2013.76118](https://www.tandfonline.com/doi/abs/10.1080/17517575.2013.76118).
- [16] Bogdon M,Et.Al,"Oil Well Diagnosis By Sensing Terminal Characteristics Of The Induction Motor",*Ieee On Industrial Electronics*, Vol.47, No.5, October 2000, Available Online : [Https://Ieeexplore.Ieee.Org/Document/873219](https://ieeexplore.ieee.org/document/873219).
- [17] Li Da Xu,"Enterprise Systems: State-Of-Art and Future Trends", *Ieee Transaction On Industrial Informatics*, Vol.7, No.4, November 2011, Available Online: [Https://Ieeexplore.Ieee.Org/Document/6011699](https://ieeexplore.ieee.org/document/6011699).
- [18] Jianchu Yao,Et.Al,"Applying The Iso/Ieee 11073 Standards To Wearable Home Health Monitoring Systems", *Journal Of Clinical Monitoring And Computing*, Vol.19, No.6,2005,Springer 2006, Available Online : [Https://Www.Ncbi.Nlm.Nih.Gov/Pubmed/16437294](https://www.ncbi.nlm.nih.gov/pubmed/16437294).
- [19] Gheorghe Sebestyen,Et.Al,"E-Health Solutions In The Context Of Internet Of Things", *Ieee 14<sup>th</sup> International Conference On E-Health Networking, Applications And Services(Healthcom)*, Available Online: [Https://Ieeexplore.Ieee.Org/Document/6857876](https://ieeexplore.ieee.org/document/6857876).
- [20] Chandana, N., Babu, E. S., Prasanna, D. L., Kumar, S. P., & Sravanthi, K. S. (2017). Conceptual Oriented Application Protocols in Internet of Things: Qualitative Performance Analysis.
- [21] Saikiran, P., Sureshbabu, E., Padmini, D., Srilalitha, V., & Krishnanand, V. Security Issues and Countermeasures of Three Tier Architecture of Iot-A Survey.
- [22] Sinha, P. K., Babu, E. S., Gupta, N., Naz, K. A., & Khatoon, H. Implementation Of Communication Protocol Stack For 6lowpan Network Domain In Internet Of Things.
- [23] Babu, E. S., Naganjaneyulu, S., Rao, P. S., & Rao, M. S. (2017). Collaborative Attack Effect against Table-Driven Routing Protocols for Wanets: A Performance Analysis. In Computer Communication, Networking and Internet Security (Pp. 69-80). Springer, Singapore. [https://doi.org/10.1007/978-981-10-3226-4\\_7](https://doi.org/10.1007/978-981-10-3226-4_7).