

Detection of Rotating Diode Failure Condition & its Protection in Brushless Alternator

Pranupa S^{1*}, Kiran Kumar B M^{2*}, S. Nagaraja Rao^{3*}

* Assistant Professor, Department of Electrical Engineering, M.S.Ramaiah University of Applied Sciences, Bangalore

*Corresponding author E-mail: pranupa.ee.et@msruas.ac.in

Abstract

Brushless excitation system is widely used in large capacity synchronous generators since it removes the usage of commutator, brushes and slip rings, hence reduces the losses, maintenance and increases reliability. Rotating Rectifier Assembly (RRA) is the main part of brushless alternator. Due to ageing phenomenon and continuous process regime, diodes in rotating rectifier can fail either due to Open Circuit (OC) or Short Circuit (SC), which overloads the exciter and hence the alternator can no longer run securely. If such condition is prolonged, the Automatic Voltage Regulator (AVR) as well as the exciter windings can be damaged.

This paper presents two different methods of diode failure detection in brushless alternators. First method uses an algorithm based on output voltage and the second uses the ripple factor of the exciter field current. Diode failure condition is detected for different type of loads connected to 4 kVA, 380 V, 50 Hz, 4 poles generator with 14 pole exciter (brushless alternator) and the results are verified using MATLAB/Simulink. Also, the protection schemes for rotating diode assembly as well as exciter field windings are presented using Metal Oxide Varistor (MOV) and Discharge Resistor.

Keywords: Brush Less Synchronous Generator (BLSG), Rotating Rectifier Bridge, Rotating Rectifier Assembly (RRA), Automatic Voltage Regulator (AVR), Metal Oxide Varistor (MOV).

1. Introduction

Three phase alternators are the main source of power generation in power plants [1]. They are capable of generating AC power at specified frequency, also called as synchronous generator and these machines are the largest energy converters in the world. Based on the excitation system, they can be grouped into brushed and brushless alternators [2]. The brushed alternator, also called as rotating armature type are used only in alternators of low power rating and generally is not used to supply electric power in large quantities. As the armature in brushed alternator is of rotating type, it requires slip rings and brushes to collect the current from the armature. However, the armature, brushes, and slip rings are difficult to insulate, which results in arc overs and short circuits at high voltages.

The brushless alternator consist of a main generator and an excitation system as shown in Fig. 1. An excitation system comprises of an exciter of rated frequency and a rotating rectifier bridge. A brushless excitation system is common in huge capacity synchronous generators as it eradicates the usage of brushes and slip rings [3], leads to decrease in maintenance and increase in reliability. The voltage generated in the armature winding can be directly connected to the load in stationary armature winding [4], its an added advantage of having a stationary armature winding. For this reason high voltage alternators are usually of the rotating field type. Since the voltage applied to the rotating field is low voltage DC, the problem of high voltage arc-over at the slip rings does not exist. Brushless excitation system is popular in alternators.

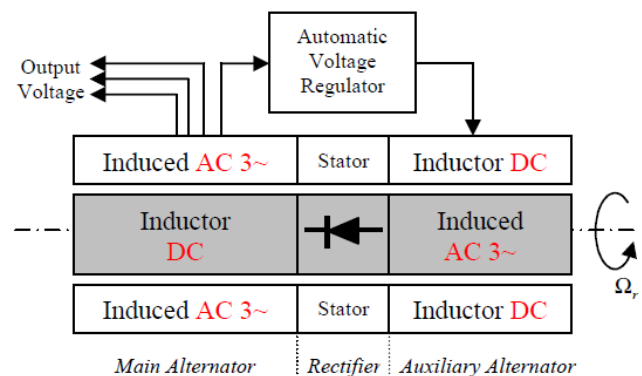

Fig. 1: Brushless Alternator

The RRA of brushless alternator are susceptible to failure. Diode failure may be due to faulty manufacturing, faulty handling, excess voltage or current surge flowing through the diode. In spite of precautions the risk of diode failure cannot be completely eliminated and therefore it is instructive to examine the effects of such failure. The most likely type of fault is short circuit failure, at times the diode may be open circuited.

There are several literatures available on various methods of diode failure detection and its protection of brushless alternators. [5], explains the diode failure detection based on the spectral analysis of the generator output voltage, the analysis of stay flux in the air gap of the machine is proposed to monitor the diode failure conditions. However, the behavior of spectral response for lagging and non-linear loads needs to be addressed.

Harmonic analysis of the output voltage waveform of an alternator is executed under no load and load conditions are used to differentiate the state of rotating diodes. Also, to distinguish short circuit diode failure case from open circuit diode breakdown, the comparative amplitudes at particular harmonics were used in [6]. A feed forward controller for a brushless excitation system during the open circuit fault operation based on Fast Fourier Transformation (FFT) is proposed in [7]. In which the machine can even operate at open circuit fault mode. Also, an OC or SC fault in the rotating rectifier were measured using harmonic analysis. A non-invasive process for identifying failure of brushless exciter rotating diode is addressed in [8]. Where the diode failure is sensed by comparing the magnitude of the fundamental component with the dc level of an exciter field current with the cost of an added current transducer to monitor the field current of an exciter.

The present work deals with the study of new rotating diode failure detection using output voltage method [5] & ripple factor method. Different schemes involved in protection of rotating rectifier bridge circuit in the exciter of alternator are presented. Analysis of the rectifier protection is made by discharge resistor and Metal Oxide Varistor (MOV).

2. Problem Statement

This work focuses on detecting diode failure and protection of diode assembly as well as alternator field winding in brushless alternator.

The present work is divided into two phases

1. Diode failure detection using:
 - a) Output voltage method and
 - b) Ripple factor method.
2. Protection of diode assembly and alternator field winding using:
 - a) Discharge resistor and
 - b) Metal Oxide Varistor (MOV)

The complete model for detecting diode failure and protection of diode assembly is built using MATLAB/Simulink as simulation tool. The following steps are involved in achieving the complete model for detection of diode failure and protection of diode.

- The brushless alternator of rating shown in Table 1 is built using MATLAB/Simulink as simulation tool
- Different types of fault conditions like short circuit, open circuit are created in rotating diode bridge of brushless alternator
- For the different types of fault conditions created in the rotating diode bridge of brushless alternator the algorithm based on output voltage method is implemented and checked for the correctness of its working
- Ripple factor of exciter field current is determined and detection of diode failure is checked
- Protection circuit using two different protective devices using discharge resistor and Metal Oxide Varistors (MOV) are built

Table 1: Rating of brushless alternator

kVA	4
Output Voltage	380V
Main Generator Frequency	50 Hz
Main Generator Poles	4
Exciter Poles	14

3. Matlab/simulink rectifier bridge model to create short and open circuit

The three phase diode bridge rectifier model considered in present work is shown in Fig. 2.

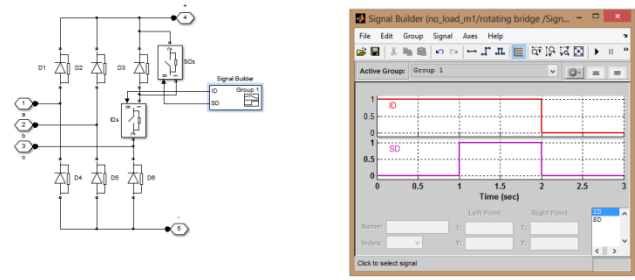

Fig. 2: MATLAB/Simulink Model of Rectifier Bridge and its Switching Time used in Brushless Alternator

Using MATLAB/Simulink software the three phase bridge rectifier used in brushless alternator is modelled. Two switches SD and ID are used to create short circuit and open circuit condition in diode bridge. The diode (D3) is made to fail. The switch ID initially is in closed state, it gets open at 2 min. Switch SD was initially in open state, it gets closed at 1 min and again goes to open state at 2 min. Here by we can see the normal working of all diodes till 1 min, short circuit condition of diode (D3) from 1 min to 2 min, open circuit condition of diode (D3) from 2 min to 3 min. The switching time is adjusted according to the design and the fault is automatically created in the bridge according to the time duration shown in Table 2.

Table 2: Fault Duration in Rotating Rectifier Assembly

Time Duration	0-1 sec	1-2 sec	2-3 sec
Diode Condition	Normal	Short circuit	Open circuit

4. Matlab Simulink Complete Model of Brushless Alternator

The MATLAB/SIMULINK model for armature and field winding is built for the rating shown in Table 1. The armature and field design procedure for the exciter and main generator both remains same but the parameters differ. The rotating rectifier as shown in Fig. 2 along with AVR is integrated to build the complete model of brushless alternator.

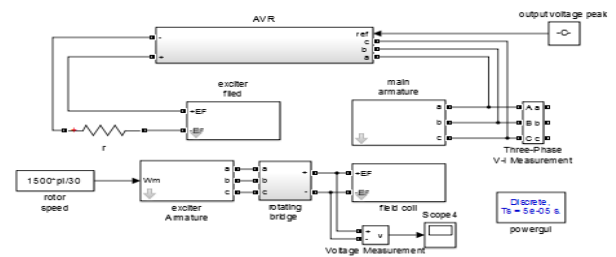

Fig. 3: MATLAB/Simulink Model of Brushless Alternator

The main generator output voltage is measured through voltage measurement block and is compared with reference voltage. The error obtained is made zero by using PID controller and the required voltage is given from AVR to the exciter field windings.

5. Detection of diode failure

5.1. Output voltage method

Monitoring the magnitude of characteristic frequencies/sideband frequencies are useful to distinguish rotating diode state by calculating the indicator value.

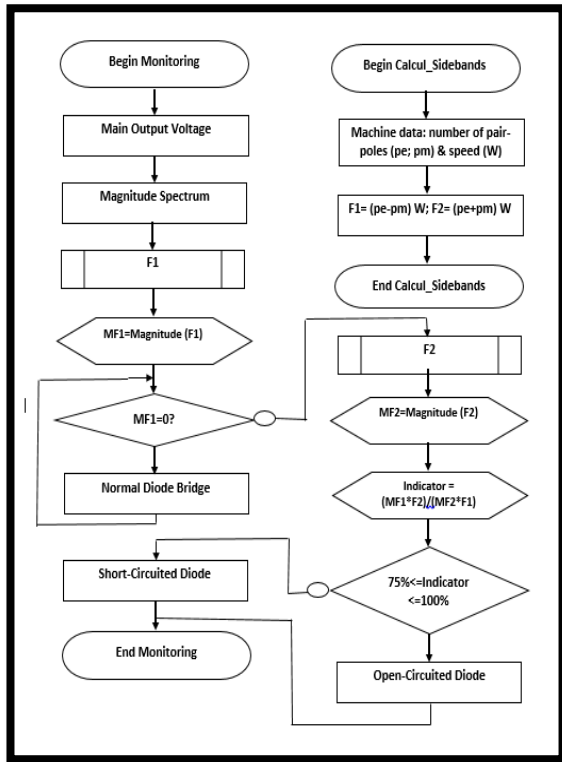

Fig. 4: Monitoring Algorithm based on Output Voltage

Voltage method implemented in brushless alternator with Resistive(R) load connected is shown in Fig. 5.

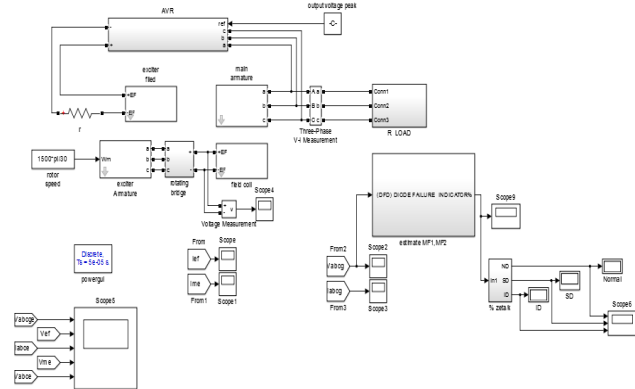

Fig. 5: MATLAB/Simulink Model of Monitoring Algorithm Implemented for Diode Failure Detection (DFD) Block connected to Brushless Alternator with R Load

The output voltage method based on Fig. 4 is built and added to the brushless alternator model in Fig. 5. This complete model is checked for Diode Failure Detection (DFD) under various conditions like for no load, R load, RL load and non-linear load connected.

5.2. Ripple Factor Method

The waveform of an exciter field current will change particularly when a rotating diode fails either due to OC or SC, results in retaining of higher amount of AC component in the waveform. The field current in the exciter is basically DC with a little AC ripple. When the diode bridge is in normal condition, with all diodes in healthy condition, there is only a small ac ripple present in the exciter field current waveform. The AC content of the waveform increases when a diode is OC. When the diode is short circuited, ac component increases further.

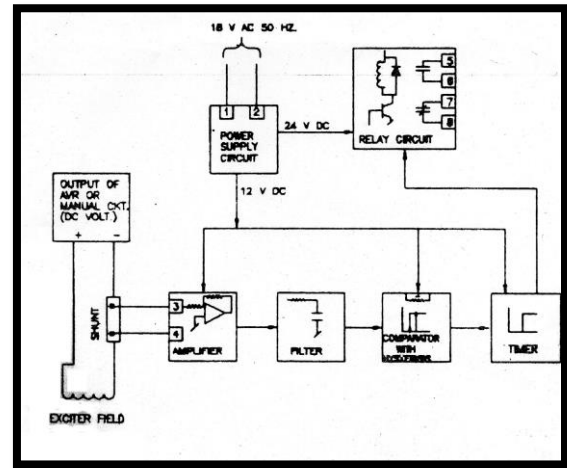

Fig. 6: Block Diagram for Measuring Ripple Factor

The ripple factor content is not dependent on the load. This helps simplifying the task of identifying the state of diode bridge. By monitoring the AC component increase in the exciter field current to relative DC current level, the diode failure can be identified. The fault monitor comprises a low pass filter and high pass filter shown in Fig. 6. This approach of diode failure detection leads to estimate the ratio of AC component of the exciter field current to the DC level of the same signal. Based on the estimated value of this ratio the diode failure can be detected.

Ripple factor method implemented in brushless alternator with non-linear load connected model used in present work is shown in Fig. 7.

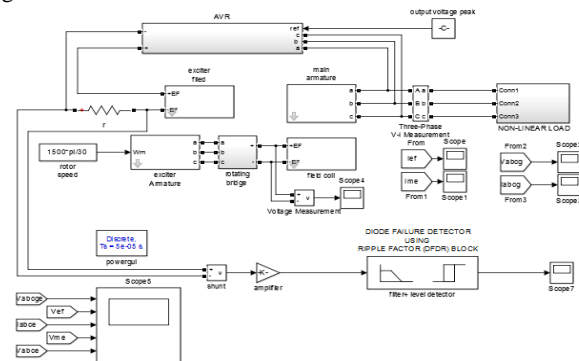

Fig. 7: MATLAB/Simulink Model of Diode Failure Detection by Ripple Factor Method Implemented in Brushless Alternator with Non-Linear Load

The ripple factor method shown in Fig. 6 is implemented using MATLAB/Simulink, which is used to detect the diode failure in brushless alternator; a shunt connected across the exciter field terminals gives the current/voltage measurement. The ratio of AC to DC component gives the ripple factor. If this factor is less than 20 percent then diode is identified to be in normal mode, if it's greater than or equal to 20 percent then diode is identified to be in failure mode. Using the same ripple factor method, its correctness is checked for no load, R load, non-linear load connected to brushless alternator.

6. Protection Schemes

In the present work the protection of diode bridge is discussed using discharge resistor and Metal Oxide Varistor (MOV).

6.1. Protection using Discharge Resistor

The discharge resistor is used as protective device for diode rectifier unit. The resistance of the discharge resistor varies according to the value of main field resistance of the alternator. Discharge

resistor serves to improve generator starting characteristics and to protect the silicon rectifier from voltage induced in the field winding when starting or when the sudden load applied to generator. Fig. 8 shows the discharge resistor connected across the main field winding.



Fig. 8: Discharge Resistor

Simulation model of protection circuit using discharge resistor in brushless alternator is shown in Fig. 9.

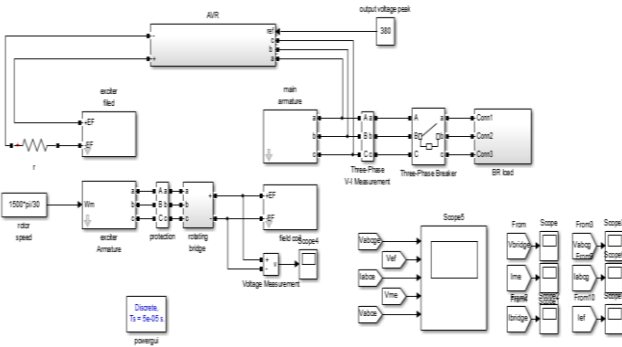

Fig. 9: MATLAB/Simulink Model for Protection of alternator using Discharge Resistor

The variation of current and voltage in the alternator is checked with and without discharge resistor connected to the rotating rectifier assembly.

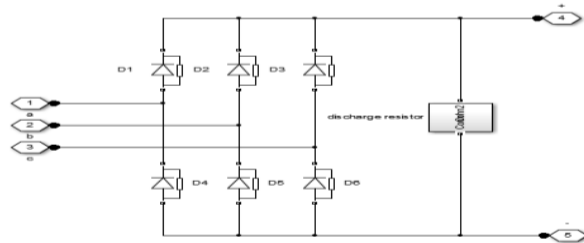

Fig. 10: MATLAB/Simulink Model of Discharge Resistor connected in between Rectifier and Main Generator

6.2. Protection using Metal Oxide Varistors

Variable resistors or varistors are voltage-dependent resistors with a symmetrical V/I Characteristic curve whose resistance decreases with increasing voltage. It is allied in parallel with the electronic device that is to be protected, it form a low resistance shunt whenever voltage increases and thus prevent any further rise in the overvoltage. Simulation model of protection using MOV in Brushless Alternator is shown in Fig. 11.

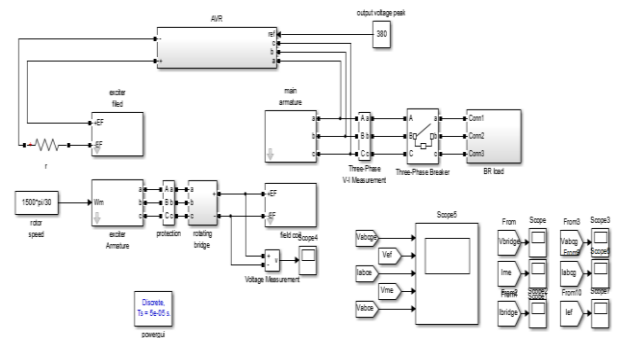

Fig. 11: MATLAB/Simulink model for protection circuit of alternator using MOV

Metal Oxide Varistor (MOV) is connected as a protection device across the bridge rectifier. The MATLAB/Simulink model of MOV is shown in Fig. 14. The MOV model consists of a circuit breaker which is initially in open state. The reference output voltage is set as 250 V, if the obtained voltage value is greater than reference voltage (250 V), it results in closing the circuit breaker.

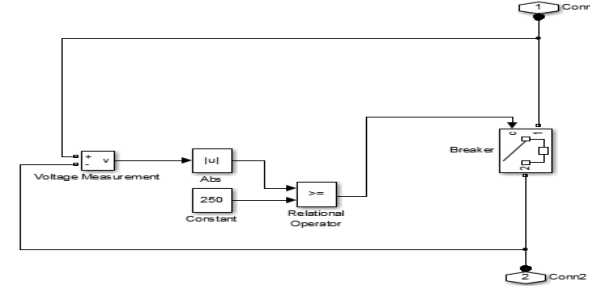

Fig. 12: MATLAB/Simulink model of MOV connected in between rectifier and main Generator

The load is applied at 0.5 min and the variation of the voltage at rectifier output is checked without protection and with protection unit for the brushless alternator using MATLAB/Simulink model.

7. Results and Discussions

The diode bridge shown in Fig. 2 is used in alternator, which consists of six diodes. The Table 2 shows the diode condition at various interval of time. The simulation considering individual diode short/open circuit condition, failing all diodes individually, it is observed that output remains the same. Here diode D3 which is present in the 3rd limb of the diode bridge shown in Fig. 2 is considered and analyzed.

7.1. Brushless Alternator Output with Diode Fault Condition

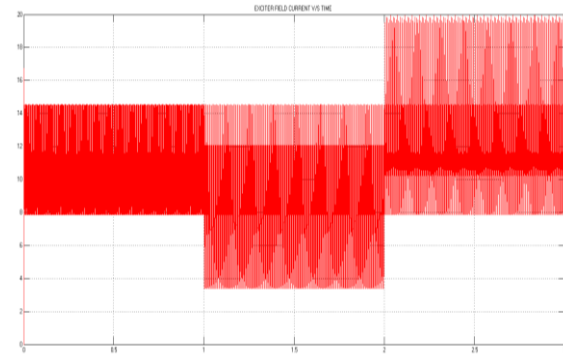

Fig. 13: Exciter field current waveform

The complete alternator model shown in Fig. 3 is made to run. The simulation model of rotating rectifier is made to run as normal condition from 0 to 1 min, short circuit condition from 1 to 2 min, open circuit condition from 2 to 3 min. The output obtained from simulation is shown in the Fig. 13. There is variation of the exciter field current due to failure of diode in brushless alternator and hence high ripple gets induced due to diode failure.

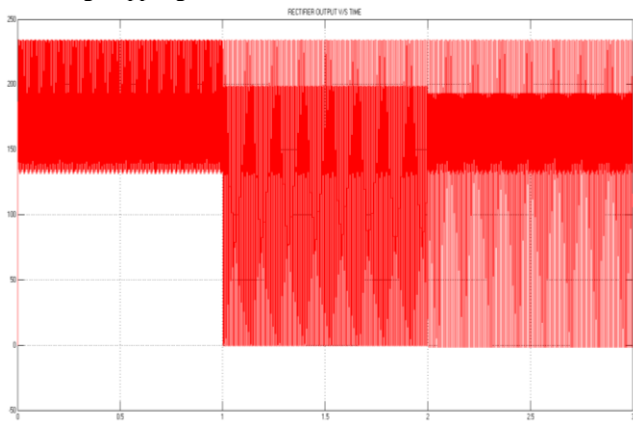

Fig. 14: Rectifier output voltage

The rectifier output voltage variation in brushless alternator due to different fault conditions is shown in Fig. 14.

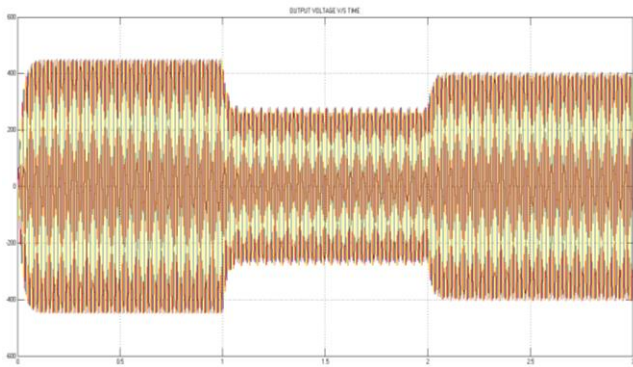

Fig. 15: Output voltage waveform

The alternator output voltage waveform under different diode fault conditions is shown in Fig. 15. The waveform shown is for the alternator with AVR disconnected. There is abrupt change in the output voltage when the diode is short circuited from 1 to 2 min.

Method 1: Output Voltage Method for Diode Failure Condition in Brushless Alternator

For the diode bridge shown in Fig. 2 the simulations were carried out, as per table 2 for indicating various conditions of diode. The correctness of the algorithm implemented in Fig. 5 is checked using output voltage method, the diode failure condition is shown in binary detectors and digital display unit. Binary detectors are used to detect the state of the diode in brushless alternator. If the detector shows one/high, that means it is in that particular state of diode failure at that instant of time.

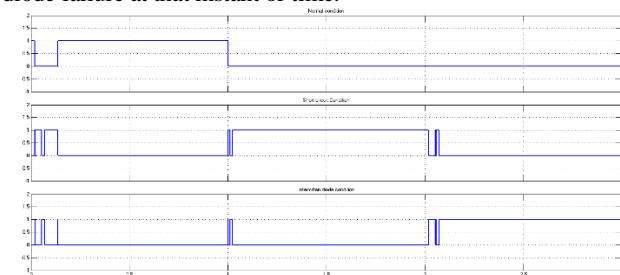

Fig. 16: Diode Fault Detection using Voltage Method shown using Binary Detectors

The output of voltage method using detectors proves it is efficient in identifying the type of fault occurred in brushless alternator for resistive load connected. The digital display unit of voltage method as shown in Fig. 17 is provided with three output displays Normal indicating the diode is in normal condition, SD indicating short circuit diode condition and ID indicating open circuit diode condition. As per the set timings of diode.

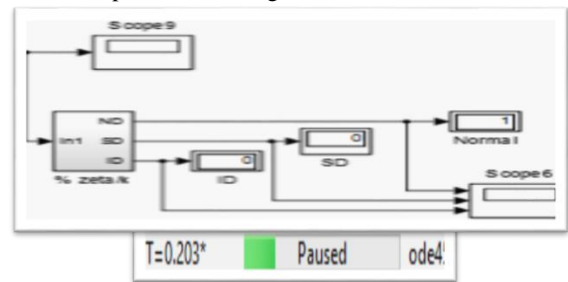

Fig. 17: Digital Display Unit of Voltage Method at 0.203 min

The normal diode condition is indicated at 0.203 min, in brushless alternator using output voltage method connected to R load.

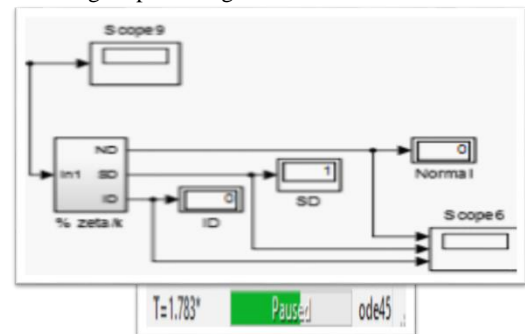

Fig. 18: Digital Display Unit of Voltage Method at 1.783 min

The short circuit diode condition is indicated at 1.783 min, in brushless alternator using output voltage method connected to R load.

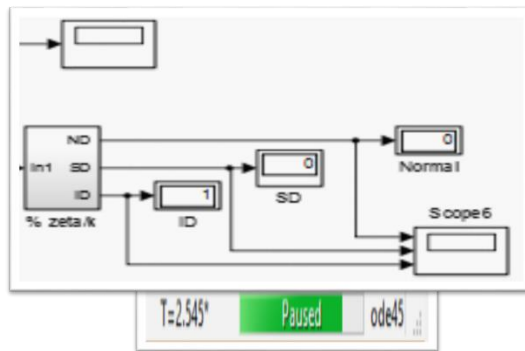

Fig. 19: Digital Display Unit of Voltage Method at 2.545 min

The open circuit diode condition is indicated at 2.545 min, in brushless alternator using output voltage method connected to R load.

The modelled alternator is made to run with no load and non-linear load implementing output voltage method. The output from binary detectors and digital display shows that for all types of fault occurred the output voltage method is efficient to detect the type of fault occurred except for non-linear load.

Method 2: Ripple Factor Method for Diode Failure Detection in Brushless Alternator

The exciter field current induces ripple due to the diode failure in brushless alternator. By measuring the ripple factor in exciter field current it is possible to detect diode failure.

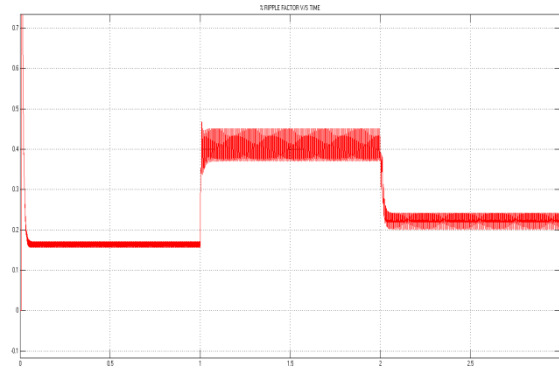

Fig. 20: Exciter Field Current Ripple with R Load Connected

When there is a diode failure the ripple factor changes distinctly, from the Fig. 20 it is shown that under normal diode condition the ripple factor is around 10 percent and during diode failure condition ripple factor is greater than or equal to 20 percent. So based on the ripple factor calculated the diode failure in brushless alternator can be determined.

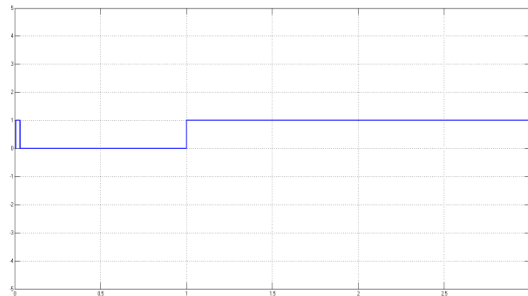

Fig. 21: Checking Correctness of the Ripple Factor Method for R Load

The binary detectors shown in Fig. 21 used as an indicator of diode failure shows that under R-load condition ripple factor method is able to detect the diode failure but not able to distinguish the type of fault (OC or SC) in brushless alternator.

The modelled alternator is made to run with no load and non-linear load implementing ripple factor method. The output from binary detectors proves that ripple factor method is efficient in detecting diode failure irrespective of the type of load applied. But not able to detect the type of fault (OC or SC).

7.2. Methods of Protection

By using the protective devices like discharge resistor and MOV the protection against the spike voltage can be provided. The output voltage of alternator remains constant before the application of load as shown in Fig. 22.

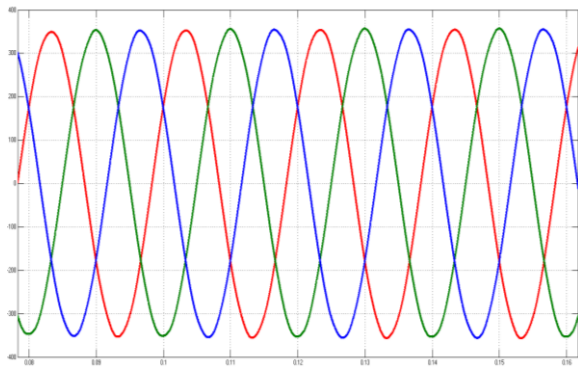

Fig. 22: No Load 3 Phase Alternator Output Voltage

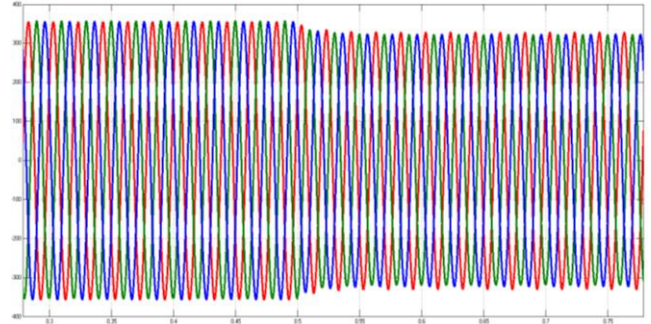

Fig. 23: Decrease in Output Voltage due to Sudden Application of Load

Due to the sudden application of the load at 0.5 min, there is fall in alternator output voltage as shown in Fig. 23.

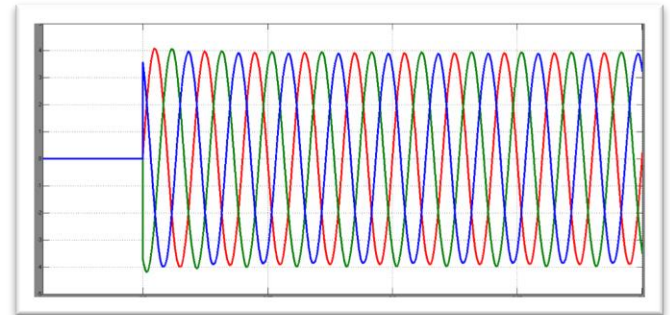

Fig. 24: Increase in Current due to Sudden Application of Load

Due to the sudden application of the load at 0.5 min, there is huge raise in alternator output current as shown in Fig. 24.

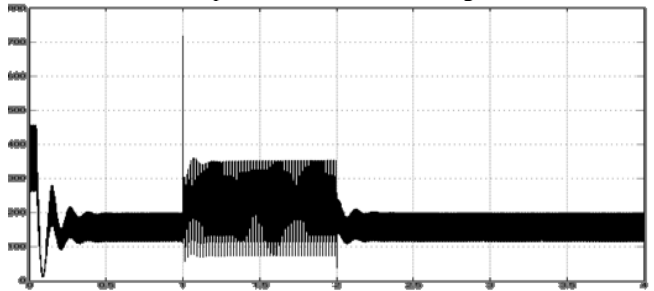

Fig. 25: Induced spikes due to sudden application of load without any protective device

Due to sudden application of load at 0.5 min, the voltage spike gets induced in the rotor of alternator, without any protective device the level of spike induced is 720 volts as shown in Fig. 25.

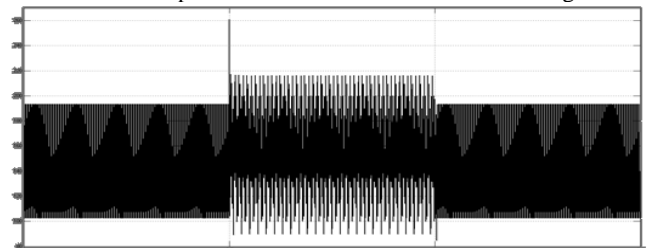

Fig. 26: Reduced Spike Level by using Discharge Resistor as a Protective Device Connected across Rectifier

Due to sudden application of load at 0.5 min, the voltage spike gets induced in the rotor of alternator, with discharge resistor as a protective device used the level of spike gets reduced from 720 to 370 volts as shown in Fig. 26.

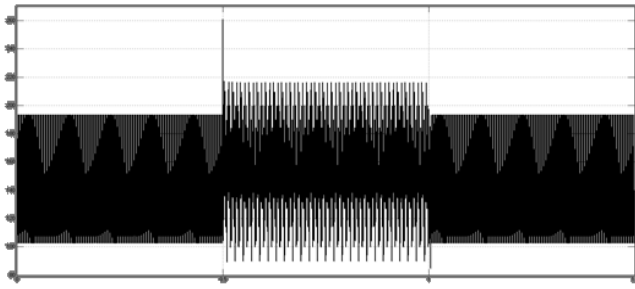

Fig. 27: Reduced Spike Level due to MOV as Protective Device Connected across Rectifier

Due to sudden application of load at 0.5 min the voltage spike gets induced in the rotor of alternator, with MOV as a protective device used the level of spike gets reduced from 720 to 260 volts as shown in Fig. 27. Hence using MOV as protective device the spike voltage can be greatly reduced.

8. Conclusion

Detection of diode failure using output voltage method and ripple factor methods are presented. From the simulation results it is concluded that the output voltage method can detect the diode fault & distinguish the type of fault occurred (whether the diodes are in normal, open circuit or short circuited) for no load and balanced R load but not able to detect for non-linear load. Ripple factor method can detect the diode failure but cannot distinguish the fault type occurred for no load, balance resistive load and Non-linear load. Ripple factor method is more suitable because it doesn't depend on the type of load connected. Protection of rotating diode assembly in brushless alternator is presented using discharge resistor and MOV. Simulation results proves that MOV's have excellent voltage clamping capabilities and response time compared to discharge resistor. Hence MOV protection scheme gives better results

Acknowledgement

Authors would like to honestly thank the Vice Chancellor and Management of M.S.Ramaiah University of Applied Sciences, Bangalore for providing all facilities required to carry out this research work

References

- [1] Zouaghi, T., &Poloujadoff, M. (1998). Modeling of polyphase brushless exciter behavior for failing diode operation. *IEEE transactions on energy conversion*, 13(3), 214-220.
- [2] Batzel, T. D., Swanson, D. C., &Defenbaugh, J. F. (2003, August). Predictive diagnostics for the main field winding and rotating rectifier assembly in the brushless synchronous generator. In *Diagnostics for Electric Machines, Power Electronics and Drives*, 2003. SDEMPED 2003. 4th IEEE International Symposium on (pp. 349-354). IEEE
- [3] Sottile, J., Trutt, F. C., &Leedy, A. W. (2006). Condition monitoring of brushless three-phase synchronous generators with stator winding or rotor circuit deterioration. *IEEE Transactions on Industry Applications*, 42(5), 1209-1215.
- [4] Salah, M., Bacha, K., Chaari, A., &Benbouzid, M. E. H. (2014). Brushless three-phase synchronous generator under rotating diode failure conditions. *IEEE Transactions on Energy Conversion*, 29(3), 594-601.
- [5] Salah, M., Bacha, K., &Chaari, A. (2013, March). Detection of brushless exciter rotating diodes failures by spectral analysis of main output voltage. In *Electrical Engineering and Software Applications (ICEESA)*, 2013 International Conference on (pp. 1-6). IEEE.

- [6] Na, W. (2011, July). A feedforward controller for a brushless excitation system during the diode open circuit fault operation. In *Power and Energy Society General Meeting, 2011 IEEE*(pp. 1-4). IEEE.
- [7] McArdle, M. G., & Morrow, D. J. (2004). Noninvasive detection of brushless exciter rotating diode failure. *IEEE Transactions on Energy Conversion*, 19(2), 378-383.
- [8] Gray, D., Zhang, Z., Apostoia, C., & Xu, C. (2009, June). A neural network based approach for the detection of faults in the brushless excitation of a synchronous motor. In *Electro/Information Technology, 2009. eit'09. IEEE International Conference on* (pp. 423-428). IEEE.
- [9] Rahnama, M., &Vahedi, A. (2016, January). Rotary diode failure detection in brushless exciter system of power plant synchronous generator. In *Thermal Power Plants (CTPP), 2016 6th Conference on* (pp. 6-11). IEEE.
- [10] Bui, H. K., Bracikowski, N., Hecquet, M., Zappellini, K. L., &Ducreux, J. P. (2017). Simulation of a large power Brushless Synchronous Generator (BLSG) with a rotating rectifier by a reluctance network for fault analysis and diagnosis. *IEEE Transactions on Industry Applications*, 53(5), 4327-4337.